

Agilent Technologies E6387A Nortel Base Station Test Software

User's Guide

Software Version: A.04.00 and later

Part Number E6387-90001

Revision E

Printed in UK

July 2001



RESTRICTED RIGHTS LEGEND

Use, duplication or disclosure by the U. S. Government is subject to restrictions as set forth in subparagraph (c) (1) (ii) of the Rights in Technical Data and Computer Software Clause in DFARS 252.227-7013.

Rights for non-DOD U. S. Government Departments and Agencies are as set forth in FAR 52.227-19 (c) (1, 2).

© Copyright 1999-2000 Agilent Technologies

Trademark Acknowledgements

Hewlett-Packard® and HP® are registered trademarks of Hewlett-Packard Company.

Microsoft®, Windows®, and MS-DOS® are registered trademarks of Microsoft Corporation.

ProComm® is a registered trademark of DataStorm Technologies, Inc.

HyperTerminal© is copyrighted by Hilgraeve, Corporation.

Agilent Technologies E6387A Support Contacts

The documentation supplied with the Test Software is an excellent source of reference, application, and service information. Please use this manual if you are experiencing technical problems.

If you have used the manual and still have *application* questions, contact the local Agilent Technologies Sales Representative.

When calling or writing for assistance, please have the following information ready:

- Instrument model number (E6380A)
- Instrument Serial Number (tag located on the rear panel).
- Installed options - if any (tag located on the rear panel).
- Firmware revision (displayed at the top of the screen when the Test Set is turned on, and also displayed on the CONFIGURE screen).
- Software revision (displayed on the SOFTWARE MENU screen when the Test Software is loaded, and also displayed on the Test Software PC Card label).

Support Telephone Numbers:

1 800 827 3848 RF Comms Service Assistance, U.S. only)

1 509 921 3848 (RF Comms Service Assistance, International)

1 800 227 8164 (Agilent Direct Parts Ordering, U.S. only)

1 877 447 7278 (Agilent Service Parts Identification, U.S. & Intl.)

Conventions Used

Special presentations of text in this manual reflect the appearance of the referenced item. Examples of these special presentations are:

Menu – A Test Set front panel key.

Pause/Continue (Reset) – A Test Set front panel *shift* function key. The key name in parentheses is the title of the function. Press the **Shift** key then the specified key to access the *shift* function.

Procedure: – Characters displayed on the Test Set screen.

k1 (Run Test) – A USER key in the key column next to the display. The words in parentheses are displayed on the screen.

Title – Titles of documentation are printed in italics.

Test Set – Refers to the Agilent Technologies 8935 Series E6380A CDMA Base Station Test Set.

Test Software – Refers to the Agilent Technologies 6387A Nortel Cell Site Test Software.

TEST – Refers to the one of the individual test modules that is part of a test procedure.

PC card – Refers to either the OTP card on which the Test Software is shipped or the SRAM card that is shipped with the Test Software for storing procedures.

PC card is an industry standard term that refers to two types of information storage cards. One meets the specifications of the Personal Computer Memory Card International Association (PCMCIA). The other meets the specifications of the Epson Corporation PC card standard. Agilent Technologies 8935 Series Test Sets use only the PCMCIA type card.

OTP card – Refers to the type of PC card that is used to store the Test Software.

SRAM card – Refers to the type of PC card that is shipped with the Test Software for storing procedures.

BTS – Refers to the Base Transceiver Station.

In procedural steps in this manual, the following words are used to describe cursor and entry actions:

- **Select** refers to scrolling the cursor to a field (**inverse video** area) and pressing the knob.
- **Enter** means to use the numeric keypad, and the **Enter** key or measurement units keys to make entries to fields. In some procedures, **enter** is used to describe the action of entering characters into a field.

In This Manual

This manual consists of the following chapters:

- **Chapter 1** – Product Description

This chapter provides a description of the Agilent Technologies E6387A Nortel Base Station Test Software.

- **Chapter 2** – Introduction to Testing

This chapter provides information on loading the Test Software, setting up the Test Software, starting the tests, and the appropriate user responses to Test Software actions.

- **Chapter 3** – Connections

This chapter provides information on equipment required for Base Station testing, and connections for cell site equipment, serial port, and printer.

- **Chapter 4** – Reference

This chapter provides detailed descriptions of the general features and functions of the Test Software. Topics are arranged alphabetically for quick and easy reference.

- **Chapter 5** – Tests, Parameters, and Specifications

This chapter describes each procedure, test, parameter, and pass/fail limits.

1. Product Description	
Agilent Technologies E6387A Nortel Cell Site Base Station Test Software	10
Items Supplied	11
Items Required	12
Additional Services Available	13
2. Introduction to Testing	
Overview	16
Loading the Test Software	17
Using the Configuration Menu Screen	21
Field Name: Return	24
Field Name: Edit Test Results Header	24
Field Name: Use BTS Laptop Utility	24
Field Name: Serial Port 9 Settings	25
Field Name: Send Test Page to BTS Laptop Utility TR Window	25
Field Name: Send Test Results to Printer at	25
Field Name: Send Test Results to	26
Field Name: Serial Port 9 Settings	26
Field Name: Print Setup	26
Field Name: Print Test Page	26
Using the More Screen	27
Field Name: Return	27
Field Name: Measure Test Cable Loss	27
Field Name: Search for Pilot PN Offset	27
Field Name: Check Even Second Clock Signal	27
Field Name: Check Markov Calls (IS-95 BTS only)	28
Field Name: Perform Return Loss Test	28
Field Name: Spectral Regrowth Test	28
Field Name: Adjacent Channel Power Test	28
Field Name: Emission Bandwidth Test	28
Field Name: Spurious Emission Test	28
Field Name: Go to RF Tools Program	28
Using the Test Menu Screen	31
Initiating Testing	32
3. Connections	
Equipment Required	34
Cell Site to Test Set Connections	36
PC and Printer Connections	46
4. Reference	
Customizing Test Procedures	50
Handling Test Results	62
Configuring the PC Terminal Program	63
Sending the Results	65
Configuring the PC Terminal Program	67
Sending the Results	69
Transferring Data to a Printer Via the SERIAL 9 Port or the HP-IB Port	71

Contents

Transferring Data to a PC Via the SERIAL 9 Port.	72
Initializing a RAM Disk	77
Initializing a PC Card	78
Operating the Test Set	79
Securing/Un-Securing Procedures	83
Test Set to GPS Time and Frequency Reference Receiver Connections.	85
Utilities	86

5. Test, Parameter, and Pass/Fail

Limit Descriptions

Procedures Supplied	88
Test Descriptions	91
Test Suite Descriptions	129
Parameter Descriptions.	139
Pass/Fail Limits Descriptions	142

1 **Product Description**

This chapter provides a description of the Agilent Technologies E6387A Nortel Cell Site Base Station Test Software.

Agilent Technologies E6387A Nortel Cell Site Base Station Test Software

The Test Software performs fast, accurate, and automated tests to determine if the RF and audio performance of Cellular Base Stations is within prescribed limits. It is used with the Agilent Technologies E6380A CDMA Base Station Test Set and various ancillary equipment in testing those Base Stations.

The Test Software may be used for the installation, maintenance, and/or repair of the following Base Stations:

- CDMA 1900
- CDMA C800
- CDMA Macro
- CDMA FCP-800
- CDMA Metro Cell SFRM 1900
- CDMA Metro Cell SFRM 800
- CDMA Rural Cell
- CDMA Metro Cell MFRM 1900
- CDMA Metro Cell MFRM 800

NOTE

The acronym MFRM stands for Multi-carrier Flexible Radio Module.

The acronym SFRM stands for Single-carrier Flexible Radio Module.

In this manual, the term Metro Cell refers to both MFRM and SFRM Base Station types.

This document is best used in conjunction with the Nortel CDMA Test Installation Method for each type of Base Station.

Items Supplied

The Test Software package contains the following listed items.

- Agilent Technologies E6387A Nortel Cell Site Base Station Test Software PC card
Agilent Technologies Part Number: E6387-10001
- Agilent Technologies E6387A Nortel Cell Site Base Station Test Software User's Guide
Agilent Technologies Part Number: E6387A-90001
- SRAM Card, 1-Megabyte
Agilent Technologies Part Number: 0950-2635
- BTS Laptop Utility
Agilent Technologies Part Number: E6961-10001
- Software Licensing Agreement

The SRAM card listed above is to be used for storing customized test programs and results, and must be initialized before use (see [“Initializing a PC Card” on page 78](#)).

Items Required

The equipment required to operate the Test Software is as follows:

- Agilent Technologies 8935 Series E6380A CDMA Base Station Test Set
- Agilent Technologies 8935 firmware revision A.04.00 or later, and DSP software revision B.03.10 or later, for best results. However, the Test Software will work acceptably with older firmware.

- Accessories:

Agilent Technologies 8935 Nortel Base Station Connection Kit

Agilent Technologies Part Number: E8302-61001

or

Other interconnect arrangements

- Optional Items:

Printer and printer connection cable for documenting test results

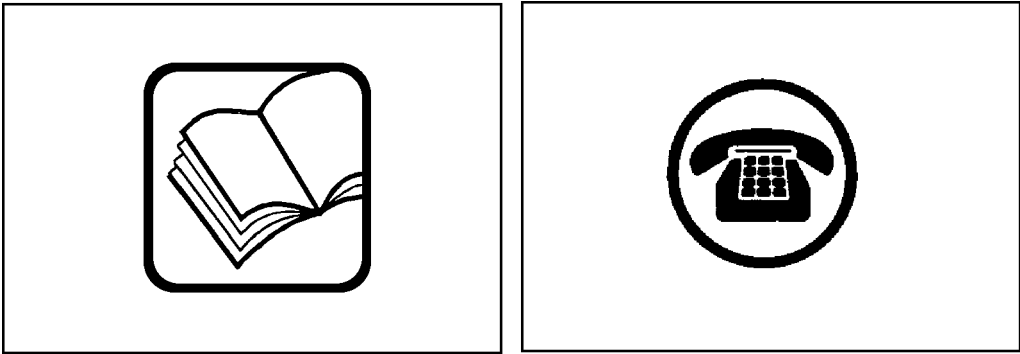
Personal computer (PC) (ordinarily a laptop PC) or an HP® Palmtop computer and appropriate connection cable for storing test results

Additional Services Available

For information on services, see the *Agilent Technologies 8935 Series E6380A CDMA Test Set Assembly Level Repair Guide*, or call the Agilent Technologies Hotline (1-800-922-8920, USA and Canada only) and supply the Test Software model number if you encounter a problem (see [Figure 1-1](#)).

Figure 1-1

Contacts

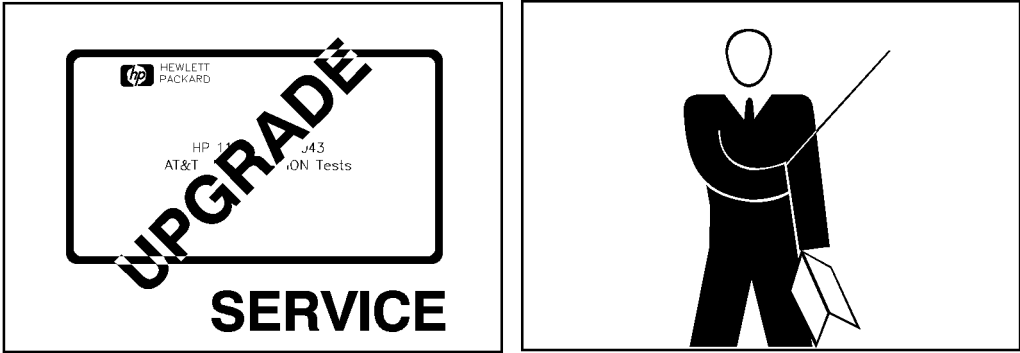


TROUBLE1

Contact the local Agilent Technologies Sales Representative for information about the Software Upgrade Service and the Start Up Assistance Training Course (see [Figure 1-2](#)).

Figure 1-2

Services



UPGRADE1

Product Description

2 Introduction to Testing

This chapter provides information on loading the Test Software, setting up the Test Software, starting the test, and the appropriate user responses to Test Software actions.

Overview

The Test Software is designed for both ease of use and comprehensive testing. Operating the Test Software consists basically of a four-part process:

1. Loading the Test Software, which consists of turning on the Test Set, inserting the Test Software card, and selecting a procedure.
2. Setting up the Test Software for test operations.
3. Initiating the tests.
4. Responding to Test Set and Test Software actions.

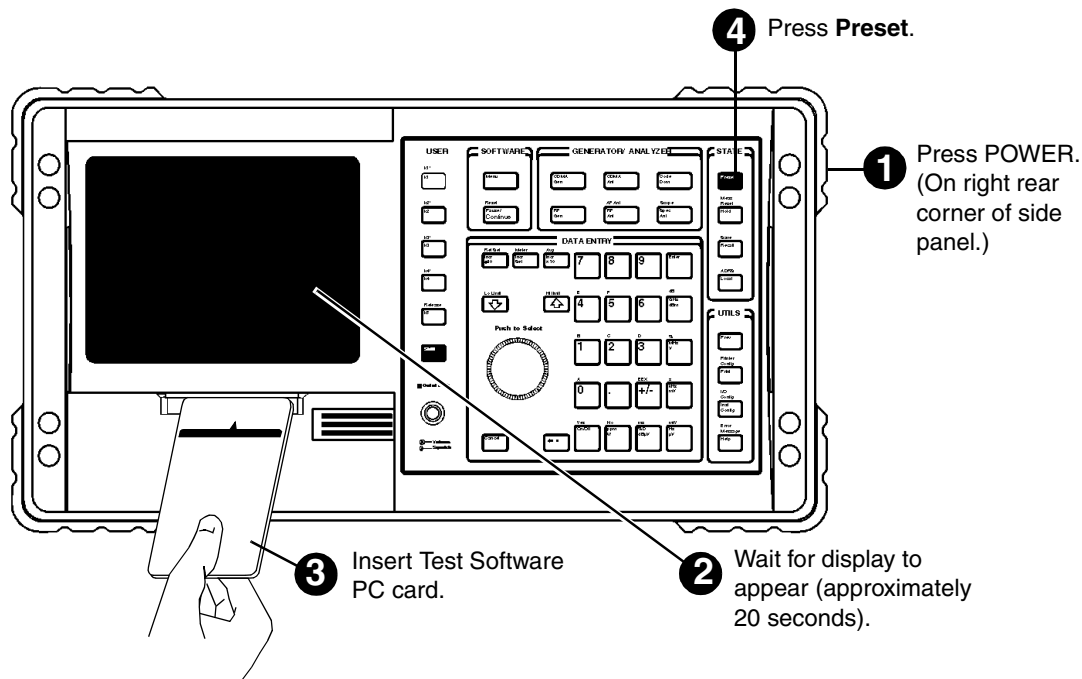
This process is described in detail in the following sections.

Loading the Test Software

Before you may begin testing, you must load the Test Software into the Test Set internal memory. The Test Software loading process is accomplished in ten steps as outlined in the following paragraphs.

The following illustration (see [Figure 2-1](#)) outlines the first four steps, which consist of turning on the Test Set power, inserting the Test Software PC card into the card slot on the Test Set front panel, and initializing the Test Set.

Figure 2-1 Preparing for Loading the Test Software



The following illustration (see [Figure 2-2 on page 19](#)) outlines the next six steps, which consist of operating the Test Set internal program to select and load the Test Software, select and load a test procedure, then run the Test Software.

NOTE

When you insert the Test Software PC card and select a procedure for the first time, the Test Software is not actually loaded into the Test Set memory until you select the **Run Test** field or press the **k1 (Run Test)** key. Loading the Test Software for the first time will require approximately 15 seconds. The Test Software will remain in the Test Set memory (power for which is backed up by a battery) after a power-off/power-on cycle unless it is deleted manually or a new program is loaded.

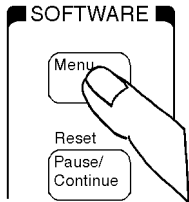











On the Test Software PC card are 10 pre-programmed procedures. Each procedure allows for performing a particular group of tests, each with parameter and pass/fail limit defaults. Briefly, the procedures are as follows:

NOTE

Each of the Test Suites mentioned in the following procedure descriptions contains one TEST group for commissioning Base Stations, and includes the standard TESTs required for Base Station installation.

- **PROCEDURE 1 – MET_1900:** This procedure is used for installation of the Nortel Metro Cell SFRM 1900-MHz Base Station. It selects [Test Suite 8 — Nortel Metro Cell 1900 MHz Install](#) as the default.
- **PROCEDURE 2 – MET_800:** This procedure is used for installation of the Nortel Metro Cell SFRM 800-MHz Base Station. It selects [Test Suite 9 — Nortel Metro Cell 800 MHz Install](#) as the default.
- **PROCEDURE 3 – MFRM1900:** This procedure is used for installation of the Nortel Metro Cell MFRM 1900-MHz Base Station. It selects [Test Suite 11 — Nortel Metro Cell MFRM 1900 MHz Install](#) as the default.
- **PROCEDURE 4 – MFRM800:** This procedure is used for installation of the Nortel Metro Cell MFRM 800-MHz Base Station. It selects [Test Suite 12 — Nortel Metro Cell MFRM 800 MHz Install](#) as the default.
- **PROCEDURE 5 – RURAL:** This procedure is used for installation of the Nortel Rural Cell Base Station. It selects [Test Suite 10 — Nortel Rural Cell Install](#) as the default.
- **PROCEDURE 6 – _1900:** This procedure is used for installation of the Nortel Legacy 1900-MHz Base Station. It selects [Test Suite 1 — CDMA 1900 MHz Install](#) as the default.
- **PROCEDURE 7 – _C800:** This procedure is used for installation of the Nortel Legacy 1900-MHz Base Station. It selects [Test Suite 3 — CDMA C800 Install](#) as the default.
- **PROCEDURE 8 – _FCP800:** This procedure is used for installation of the Nortel Legacy 1900-MHz Base Station. It selects [Test Suite 7 — CDMA FCP800 Install](#) as the default.
- **PROCEDURE 9 – _MACRO:** This procedure is used for installation of the Nortel Legacy 1900-MHz Base Station. It selects [Test Suite 5 — CDMA Macro Install](#) as the default.

Figure 2-2 Loading the Test Software

<p>5 Press Menu key to display SOFTWARE MENU screen.</p> 	<p>6 Scroll to Select Procedure Location: and select it.</p> <p>Position</p>  <pre>LOAD TEST PROCEDURE: Select Procedure Location: ██████ Select Procedure Filename: ██████</pre> <p>Select</p> 
<p>7 Scroll to Card and select it.</p> <p>Position</p>  <pre>Choices: █ Card ROM RAM</pre> <p>Position</p> 	<p>8 Scroll to Select Procedure Filename: and select it.</p> <p>Position</p>  <pre>LOAD TEST PROCEDURE: Select Procedure Location: Card Select Procedure Filename: ██████</pre> <p>Select</p> 
<p>9 Scroll to a name in Choices: list and select it.</p> <p>Position</p>  <pre>Choices: █ MET_1900 MET_800 MFRM1900 MFRM800 RURAL _1900 _C800 _FCP800 _MACRO</pre> <p>Select</p> 	<p>10 Scroll to Run Test and select it. The Test Software loads.</p> <p>Position</p>  <pre>1 Run Test 2 Continue 4 Help</pre> <p>Select</p>  <p>  Loading Time: First time: approximately 15 seconds. After first time: approximately 5 seconds. </p>

If the Test Software did not load properly, check the following:

- Is the power on? Check the AC power connection. See the *Agilent Technologies 8935 Series E6380A CDMA Base Station Test Set Reference Guide*.
- Is the Test Software PC card inserted properly?
- Is the Test Software PC card firmly seated in the slot?
It should slide in loosely, then require a firm push to seat properly.
- Was the SOFTWARE MENU screen displayed?
Pressing the **Preset** key should display the CDMA ANALYZER screen.
Pressing the **Menu** key should display the SOFTWARE MENU screen.

NOTE

If the Test Set displays an error message that states, “**One or more self-tests failed.**”, there is a hardware problem. In such case, refer to the *Agilent Technologies 8935 Series E6380A CDMA Base Station Test Set Assembly Level Repair Guide*, as appropriate. If the problem persists, call the Agilent Technologies Factory Hotline from anywhere in the USA or Canada (1-800-922-8920), 8:30 AM to 5:00 PM, Pacific time.

Using the Configuration Menu Screen

If you press the **k1 (Run Test)** key, the Test Software will display the Configuration Menu screen upon initiation of the software and prior to running any procedure. All Test Software operations are started from this screen.

The functions of the USER keys on the Configuration Menu screen are as follows.

- **k1 (Test Menu)** – Press to display the Test Menu screen.
- **k2 (Test Res)** – Press to display the Test Results/Laptop Util/Printer/Serial Setup screen.
- **k3 (More)** – Press to display the More screen.
- **k4 (Dig Gains)** – Pressing this key displays the Digital Gains screen. This screen shows the recommended Base Station digital gains and OCNS channels and the resulting Base Station power output. The screen also includes a calculator that allows you to input alternate digital gains and OCNS channels and derive the resulting output power.

NOTE

The Base Station power output is dependent on the digital gain settings of the pilot channel, paging channel, sync channel, and OCNS channel. It is also dependent upon the number of OCNS channels that are active. Once a Base Station is in service, the gains will be set to optimize the wireless network performance. During testing, there are recommended gain settings that are more than likely different than the in-service gain settings. These recommended settings result in a desired Base Station power output.

Ideally, you should change the Base Station gain settings when you test the Base Station. However, this might not always be practical. Therefore, you may use the Digital Gain screen to determine the new Base Station power output based on the gain settings in the Base Station.

You may use the Vortex PC Power Palette Window to set the digital gains in the Base Station.

- **k5 (Quit)** – Press to cause the Test Software to terminate configuration operations.

The following sections describe the fields and the operations that may be initiated.

Test Menu

Select the **Test Menu** field or press the **k1 (Test Menu)** key to display the Test Menu screen.

Channel

Select the **Channel** field to enter the channel number to be tested.

Channel Standard

Select the **Channel Standard** field to enter the choice for band from the **Choices:** list.

If the Test Suite selected in the **Test Type** field is that of a 1900-MHz type Base Station, the choices available are **North American PCS** and **Korean PCS**.

If the Test Suite selected in the **Test Type** field is that of an 800-MHz type Base Station, the choice available is **North American Cell**.

CDMA Standard

Select the **CDMA Standard** field to enter the choice for band from the **Choices:** list.

If the Test Suite selected in the **Test Type** field is that of a Metro Cell or Rural Cell Base Station, the choices available are **IS-95** and **IS-2000 1xRTT**.

If the Test Suite selected in the **Test Type** field is that of any other type Base Station, the choice available is **IS-95**.

Base Station PN Offset

Select the **Base Station PN Offset** field to enter the PN offset for the Base Station to be tested.

Sector

Select the **Sector** field to enter the choice for the sector to be tested from the **Choices:** list.

NOTE

If you selected a Metro Cell or Rural Cell Base Station in the **Test Type** field, the **Choices:** list offers four items each for Alpha, Beta, and Gamma sectors. If you selected any type Base Station other than a Metro Cell or Rural, the list offers only one item for each sector.

Base Station Power Out

Select the **Base Station Power Out** field to enter in dBm the value to be used in the Base Station power output testing. In the instance of an MFRM Base Station, enter the total power output of all three MFRM carriers.

NOTE

The Base Station power out is dependent on the digital gain settings and the number of active OCNS channels. If you wish to determine the power output based on the digital gain settings in the Base Station, press the **k4 (Dig Gains)** key. This will display a screen on which you may calculate the power output.

Carrier Power Out

This field is applicable only to MFRM Base Stations. Select the **Carrier Power Out** field to enter in dBm the value (of the power output of each individual carrier) to be used in testing the absolute power value in the MFRM Total Power Test.

Test Cable 1 (TC1) Loss

Select the **Test Cable 1 (TC1) Loss** field to enter in dB the measured value of the loss through Test Cable 1.

Test Cable 2 (TC2) Loss

Select the **Test Cable 2 (TC2) Loss** field to enter in dB the measured value of the loss through Test Cable 2.

External Attenuator Loss

Select the **External Attenuator Loss** field to enter in dB the measured value of the loss through the external attenuator to be used in testing.

NOTE

The external attenuator typically *is not* used for testing Legacy Base Stations, but it typically *is* used for testing Metro Cell and Rural Cell Base Stations.

Tests on Legacy Base Stations typically are performed at 4 watts, which does not exceed the maximum level of 15 watts for the RF IN/OUT port of the Test Set. However, tests on Metro Cell and Rural Cell Base Stations are performed at 20 watts and 100 watts, respectively, which does exceed the maximum level. Thus, the attenuator is required for Metro Cell and Rural Cell Base Station testing.

Test Type

Select the **Test Type** field to enter the choice for the Test Suite from which testing is to be performed from the **Choices:** list. The Test Suite name indicates the type of Base Station to be tested.

Cabinet

Select the **Cabinet** field to enter the choice for the cabinet style (indoor or outdoor) from the **Choices:** list. This field is applicable for Metro Cell and Rural Cell Base Stations only.

Carr Conf

Select the **Carr Conf** field to enter the choice for the carrier configuration of the Base Station from the **Choices:** list. This field is applicable for Metro Cell and Rural Cell Base Stations only.

NOTE

Metro Cell Base Stations (except MFRM types) are of four basic configurations: 1-carrier, 2-carrier, 3-carrier, and 4-carrier. For example, the carriers in a 4-carrier configuration in the **Choices:** list are identified as 1st, 2nd, 3rd, and 4th.

Rural Cell Base Stations are of two basic configurations: 1-carrier, and 2-carrier. These are identified in similar fashion.

Metro Cell MFRM Base Stations occur in a broader variety of configurations in the **Choices:** list.

RX Conf

Select the **RX Conf** field to enter the choice for configuration regarding a receiver splitter from the **Choices:** list. This field is applicable for 800-MHz SFRM Metro Cell, MFRM Metro Cell, and Rural Cell Base Stations only.

NOTE

If only one splitter is listed, it is the splitter for both the RX0 and RX1 paths.

If two splitters are listed, the first is for the RX0 (main) path, and the second is for the RX1 (diversity) path.

TX Conf

Select the **TX Conf** field to enter the choice for configuration regarding an IMF or Combiner from the **Choices:** list. This field is applicable for Metro Cell 800-MHz and Rural Cell Base Stations only, but note that the choices are different for the two types.

Test Results/Laptop Util/Printer/Serial Setup

Select the **Test Results/Laptop Util/Printer/Serial Setup** field to display the Test Results/Laptop Util/Printer/Serial Setup screen. The Test Results/Laptop Util/Printer/Serial Setup screen fields are described in the following paragraphs:

Field Name: Return

Select the **Return** field to return to the Configuration Menu screen.

Field Name: Edit Test Results Header

Select the **Edit Test Results Header** field to edit or enter the header text. Edit or add text using selections from the **Choices:** list in the lower right-hand area of the screen. The text will appear as entered in the box at the top of the screen.

Select **Done** when finished. The text that you edited or entered will then appear at the beginning of the test results.

Field Name: Use BTS Laptop Utility

NOTE

The BTS Laptop Utility is a PC-based program that allows you to view and save test results on a PC. If the utility is loaded on the PC, and you wish to send the test result to the PC, toggle this field to **Yes**. For more information on this subject, see [“Sending Test Results to a PC Using the BTS Laptop Utility” on page 62](#).

Select the **Use BTS Laptop Utility** field to select whether you wish to use the utility. When you select the field, the **Yes/No** section of the field will toggle.

If it is set to **No**, and you toggle it to **Yes**, two fields will be displayed below: **Serial Port 9 Settings**, and **Send Test Page to BTS Laptop Utility TR Window**. These fields are described starting on this page.

If it is set to **Yes**, and you toggle it to **No**, five fields will be displayed below: **Send Test Results to Printer at**, **Send Test Results to**, **Serial Port 9 Settings**, **Print Setup**, and **Print Test Page**.

Toggle to Yes -- If you toggle the **Use BTS Laptop Utility** field to **Yes**, set the two fields as described in the following two sub-sections.

Field Name: Serial Port 9 Settings

NOTE

For the Test Set to communicate with the PC, the SERIAL 9 port configuration on the Test Set and the PC must match. This field allows you to configure the Test Set port to match the PC port.

Select the **Serial Port 9 Settings** field to configure the SERIAL 9 port. The Test Software will display the Serial Port 9 Settings screen. This screen allows you to match the configuration of the SERIAL 9 port to that of the port of the PC or similar device to which data will be transmitted. For each field, select from the **Choices:** list.

- For **Serial Baud**, select **300** to **115200** baud.
- For **Parity**, select **None**, **Odd**, **Even**, **Marking**, or **Spacing**.
- For **Data Length**, select **7 bits** or **8 bits**.
- For **Stop Length**, select **1 bit** or **2 bits**.
- For **Flow Control**, select **None**, **Xon/Xoff**, or **Hardware**.

Select the **Return** field or press the **k5 (Return)** key when finished to return to the previous screen.

Field Name: Send Test Page to BTS Laptop Utility TR Window

Select the **Send Test Page to BTS Laptop Utility TR Window** field to test the connection between the Test Set and the PC that is running the BTS Laptop Utility program. The Test Software will transmit one page of data to the BTS Laptop Utility program **Test Results (TR)** window as a test.

Toggle to No -- If you toggled the **Use BTS Laptop Utility** field to **No**, set the six fields as described in the following six sub-sections.

Field Name: Send Test Results to Printer at

NOTE

Test results always appear on the Test Set display. In addition, you may direct the Test Software to send the results to a printer.

Select the **Send Test Results to Printer at** field to indicate to the Test Software the port address of the printer connection. Select the address from the **Choices:** list. If you select **Off**, no port will be used for transmitting test results to a printer. If you select **Serial 9**, **Parallel 15**, or **HP IB**, the selected port will be used for transmitting test results to a serial, parallel, or HP-IB printer, respectively. If you select the HP-IB printer, you must enter its address in the field. For more information, see [“Stop Sending Test Results to a Printer” on page 76](#), [“Sending Test Results to a Parallel Printer” on page 74](#), and [“Sending Test Results to an HP-IB Printer” on page 75](#).

Field Name: Send Test Results to

NOTE

In addition to test results appearing on the Test Set display, those results may be saved on an SRAM card or sent to a PC connected to the SERIAL 9 port. If you wish to send the results to a printer and also to a PC, this will require the use of a PC communication program such as ProComm®.

Select the **Send Test Results to** field to indicate to the Test Software the destination to which you wish to send test results. Select the destination from the **Choices:** list.

- If you select **Off**, the Test Software will assume no destination (other than the Test Set display) for test results.
- If you select **Serial 9**, the Test Software will transmit the test results to a device connected to the SERIAL 9 port. For more information, see [“Sending Test Results to a PC” on page 66](#).
- If you select **PC Card**, the test results will be sent to an SRAM card. In such case, you must insert an initialized SRAM card into the Test Set card slot. For more information, see [“Sending Test Results to an SRAM Card” on page 69](#).

Field Name: Serial Port 9 Settings

Select the **Serial Port 9 Settings** field to configure the SERIAL 9 port. See the earlier description of this field.

Field Name: Print Setup

Select the **Print Setup** field to set the print configuration. The Test Software will display the Print Setup screen.

- Enter the desired value for the **Lines/Page** field.
- Set the toggles appropriately for the **Form Feed at Start of Page** and **Form Feed at End of Page** fields.
- Select the **Printer Model** field to choose the printer model from the **Choices:** list.

Select the **Return** field or press the **k5 (Return)** key to return to the previous screen.

Field Name: Print Test Page

Select the **Print Test Page** field to check the connection between the Test Set and the printer before a test. The Test Software will send one test page of data to the printer.

A printer must be connected to a Test Set port and set up for printing, and the **Send Test Results to Printer at** field must be set to the port to which the printer is connected in order to print a test page.

Using the More Screen

Select the **More** field on the Configuration Menu screen to display the More screen. Dependent upon the type of Base Station, one of two screens will appear.

- If the Test Suite selected in the **Test Type** field is that of a Legacy 1900-MHz type Base Station, the screen will include all of the following 12 fields.
- If the Test Suite selected in the **Test Type** field is that of a Metro Cell or Rural Cell, or Legacy 800-MHz type, the screen will include only the first 5 of the following 12 fields.

Return

Select the **Return** field or press the k5 (**Return**) key to display the initial Configuration Menu screen again.

Utilities Menu

Select the **Utilities** field to display the Utilities Menu screen. The Utilities Menu screen fields are described in the following paragraphs:

Field Name: Return

Select the **Return** field to return to the Configuration Menu screen.

Field Name: Measure Test Cable Loss

Select the **Measure Test Cable Loss** field to initiate the measurement. The Test Software will display the first of a series of cable loss test connection diagrams. Follow the screen prompts to make the measurement. Save the value for each measurement in turn by pressing the **k3 (Save Data)** key.

After the process for measuring the losses through the test cables, the Test Software will also offer the option of measuring the loss through an attenuator. Again, follow the on-screen prompts if you wish to make the measurement.

Field Name: Search for Pilot PN Offset

Select the **Search for Pilot PN Offset** field to direct the Test Software to derive the PN offset from the Base Station transmission. The Test Software will display a connection diagram. Follow the screen prompts to make the measurement.

Field Name: Check Even Second Clock Signal

Select the **Check Even Second Clock Signal** field to verify that the EVEN SECOND CLOCK signal from the Base Station is present. The Test Software will display two connection diagrams. Follow the on-screen prompts to check the signal.

Field Name: Check Markov Calls (IS-95 BTS only)

Select the **Check Markov Calls (Legacy BTS)** field to run a test that monitors and logs the active Walsh codes when the BTS Markov call test is run for Legacy Base Stations. The Test Software will display instructions and a connection diagram. Follow the on-screen prompts to check the calls.

Field Name: Perform Return Loss Test

Select the **Perform Return Loss Test** field to initiate the measurement. The Test Software will display the Swept Return Loss Setup screen. Select the **Start Frequency in MHz** field and enter the start frequency, select the **Stop Frequency in MHz** field and enter the stop frequency, then press the **k1 (Begin Tst)** key to invoke the test. The Test Software will display two connection diagrams and on-screen prompts to direct the measurement process.

Field Name: Spectral Regrowth Test

Select the **Spectral Regrowth Test** field to initiate the test to verify that the Base Station is within its assigned 1.23-MHz bandwidth and is not generating any out-of-channel power. This test is the same as the Spectral Regrowth Test used in multiple Test Suites. See the description of the [“Spectral Regrowth Test” on page 126](#) for details.

Field Name: Adjacent Channel Power Test

Select the **Adjacent Channel Power Test** field to initiate the test to verify the power in an adjacent channel relative to the power of the 1.23-MHz carrier. This test is the same as the Test Suites for Metro Cell and Rural Cell Base Stations. See the description of the [“Adjacent Channel Power Test” on page 95](#) for details.

Field Name: Emission Bandwidth Test

Select the **Emission Bandwidth Test** field to initiate the test that measures the emissions relative to two points centered around the carrier to verify that the emissions outside of those points are attenuated at least 26 dB below the transmitter power. See the description of the [“Emission Bandwidth Test” on page 101](#) for details.

NOTE

If the Base Station is a 1900-MHz Metro Cell type, the following field will also appear on the Utilities screen.

Field Name: Spurious Emission Test

Select the **Spurious Emission Test** field to initiate the three tests that measure in-band spurious emissions within a PCS block, spurious emissions in a 1-MHz range above and below the PCS block, and spurious emissions within the PCS band, but outside of the PCS block tested in the in-band emissions test. See the description of the [“Spurious Emission Test” on page 127](#) for details.

Field Name: Go to RF Tools Program

Select the **RF Tools** field to initiate loading the RF tools utilities. The Test Software will display the introductory screen that explains loading the RF Tools. For more information on RF Tools, see the *Agilent Technologies 8935 Series E6380A CDMA Base Station Test Set Reference Guide*.

Site Name

Select the **Site Name** field to enter the name of the cell site. Enter the characters in the cell site name from those available in the **Choices:** list. Select **Done** when finished.

Show Drawings with Test

Select the **Show Drawings with Tests** field to select whether connection diagrams will be displayed during the testing process. Press the knob to toggle the setting.

Use LNA for Spec Interfer

Select the **Use LNA for Spec Interfer** field to select whether a low-noise amplifier (LNA) will be used during the Spectral Interference Evaluation TEST. Press the knob to toggle the setting.

RFFE at Remote Location

Select the **RFFE at Remote Location** field to indicate to the Test Software whether the RFFE is remotely located. Press the knob to toggle the setting.

If you select **Yes** in this field, the Test Software will display connection diagrams showing the TX and RX1 cables to the remote RFFE for performing tests on that unit. The Test Software will use the loss values entered into the following six fields to compensate for the additional cable loss.

NOTE

For each of the following six fields, include also the loss of the jumper cables used temporarily to connect the subject cable to the RFFE output. If you have not recorded the loss values for the cables, use the Determine Cable Loss Insertion Factors TEST (see [page 99](#)) to determine those values.

Alpha TX/Jumper Loss to RFFE

Select the **Alpha TX/Jumper Loss to RFFE** field to enter the value of the loss of the TX cable and jumper cable running from the Base Station to the remote RFFE. Turn the cursor control knob to change the setting, then press the knob to enter the selected setting.

Alpha RX1/Jumper Loss to RFFE

Select the **Alpha RX1/Jumper Loss to RFFE** field to enter the value of the loss of the RX1 cable and jumper cable running from the Base Station to the remote RFFE. Turn the cursor control knob to change the setting, then press the knob to enter the selected setting.

Beta TX/Jumper Loss to RFFE

Select the **Beta TX/Jumper Loss to RFFE** field to enter the value of the loss of the TX cable and jumper cable running from the Base Station to the remote RFFE. Turn the cursor control knob to change the setting, then press the knob to enter the selected setting.

Beta RX1/Jumper Loss to RFFE

Select the **Beta RX1/Jumper Loss to RFFE** field to enter the value of the loss of the RX1 cable and jumper cable running from the Base Station to the remote RFFE. Turn the cursor control knob to change the setting, then press the knob to enter the selected setting.

Gamma TX/Jumper Loss to RFFE

Select the **Gamma TX/Jumper Loss to RFFE** field to enter the value of the loss of the TX cable and jumper cable running from the Base Station to the remote RFFE. Turn the cursor control knob to change the setting, then press the knob to enter the selected setting.

Gamma RX1/Jumper Loss to RFFE

Select the **Gamma RX1/Jumper Loss to RFFE** field to enter the value of the loss of the RX1 cable and jumper cable running from the Base Station to the remote RFFE. Turn the cursor control knob to change the setting, then press the knob to enter the selected setting.

Using the Test Menu Screen

If you select a Test Suite, the Test Software will display a Test Menu screen. The content of that screen will depend upon the particular Base Station Test Suite selected, but it will include all of the TESTs required for that particular Base Station type.

For a list of the TESTs for each Base Station type, see the [“Test Suite Descriptions” on page 129](#).

You may invoke any TEST, or you may invoke a sequence of TESTs (one at a time, in any order).

Initiating Testing

After setting all relevant fields on the Configuration Menu screen to appropriate values and settings, prepare to select the TESTs by either selecting the **Test Menu** field or pressing the **k1 (Test Menu)** key. Select the TEST from the Test Menu screen.

3 **Connections**

This chapter provides information on equipment required for Base Station testing, and connections for cell site equipment, serial port, and printer.

Equipment Required

The following equipment is required for testing:

- Cellular Site Base Station to test.
- Agilent Technologies 8935 Series E6380A CDMA Base Station Test Set.
- Agilent Technologies 8935 Nortel Base Station Connection Kit. (Recommended, but not required.)

Accessory Kit Cables, Connectors, and Small Accessories

The cables, connectors, and small accessories listed in [Table 3-1](#) may be purchased together in the Agilent Technologies 8935 Nortel Base Station Connection Kit (Agilent Technologies Part Number: E8302-61001) or separately through a local vendor.

CAUTION

The Test Set and other equipment in this test system are susceptible to damage by transient RF power, continuous RF power, high voltage, electrostatic discharge from cables and other sources, and transients caused by lightning. Connections to equipment, switch settings, and power-on conditions must be selected and accomplished carefully to reduce the risk of damage to the equipment.

Table 3-1 **Accessory Kit Contents**

Description	Purpose	Quantity	Part Number
Cable, DB25(m)-to-DB9(f), 15 ft.	Accessory.	1	E8302-61005
Cable, BNC(m)-to-BNC(m), RG400, 20-ft.	Connects 10-MHz Reference and Even Second Clock signals between Base Station and Test Set.	2	E8302-61003
Cable, N(m)-to-N(m), RG214, 20-ft.	Connects Test Set RF IN/OUT connector to Base Station TX output connector. Connects Test Set DUPLEX OUT connector to Base Station RX input connector.	2	08921-61056
Cable, N(m)-to-N(m), RG214, 2-ft.	Jumper cable for remote RFFE testing.	1	E8300-61005
Cable, DB25(f)-to-Bantam	Accessory.	1	08921-61034
Cable, BNC(m)-to-Bantam	Accessory.	2	8120-8745
Cable, RJ45(m)-to-RJ45(m), 4-ft.	Accessory.	1	8120-6343
Cable, DB9(f)-to-DB9(f), null, 10-ft.	Connects Test Set to PC.	1	5182-4794
Cable, SMA(m)-to-SMA(m)	Accessory.	2	83204-61011
Attenuator, N(m)-to-N(f), 6-dB	Accessory, cable loss test.	2	0955-0819

Table 3-1 Accessory Kit Contents

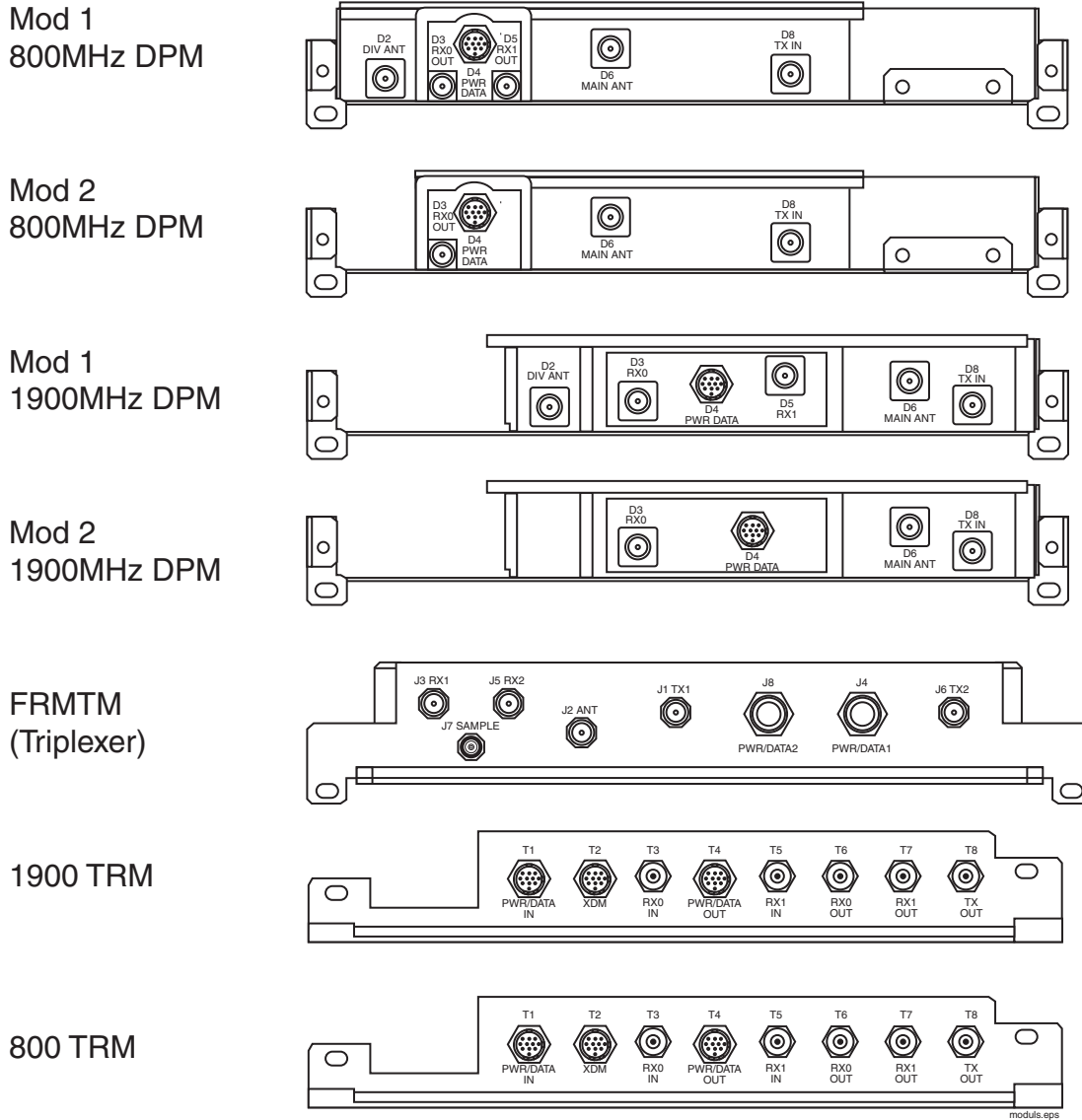
Description	Purpose	Quantity	Part Number
Attenuator, N(m)-to-N(f), 10-dB, 100-W	Used in high-power testing.	1	0955-1346
Adapter, N(f)-to-BNC(m)	Adapts N-to-N cable to Base Station connectors.	1	1250-0077
Adapter, N(f)-to-N(f)	Connects reference cable to cable or device under test in cable loss test.	2	1250-0777
Adapter, N(f)-to-SMA(f)	Adapts N to N cable to the FCP Base Station.	2	1250-1404
Adapter, BNC(m)-to-Banana(f), single	Accessory.	2	1250-2164
Adapter, N(f)-to-TNC(m)	Adapts N to N cable to Base Station connectors.	1	1250-2361
Adapter, N(f)-to-TNC(f)	Adapts N to N cable to Base Station connectors.	1	1250-2362
Adapter, BNC(m)-to-Dual Banana(m)	Accessory.	1	1251-2277
Adapter, DB25(f)-to-RJ45(f)	Accessory.	1	08921-61027

Cell Site to Test Set Connections

Many arrangements of test equipment and cell site equipment are possible. After you set up the system, you must calibrate some system components before initiating testing. After calibration, tests must be performed with the equipment connected in the same way that it was connected when calibrated.

As aids to understanding the connection diagrams shown on the screen of the Test Set, see [Figure 3-1](#), [Figure 3-2](#), [Figure 3-3](#), [Figure 3-4](#), [Figure 3-5](#), [Figure 3-6](#), [Figure 3-7](#), [Figure 3-8](#), and [Figure 3-9](#) starting on the next page for connection diagrams for the various typical Base Station configurations. Note that, because of the many configurations of Metro Cell and Rural Cell Base Stations, no Metro Cell/Rural Cell connection diagram is shown. Instead, [Figure 3-1](#) shows Metro Cell and Rural Cell modules to assist in identifying connection locations.

Figure 3-1 1900/800-MHz Metro Cell and Rural Cell Base Station Connection Locations



Connections

Figure 3-2 CDMA Macro Base Station RX0 Receive Path Connection Diagram

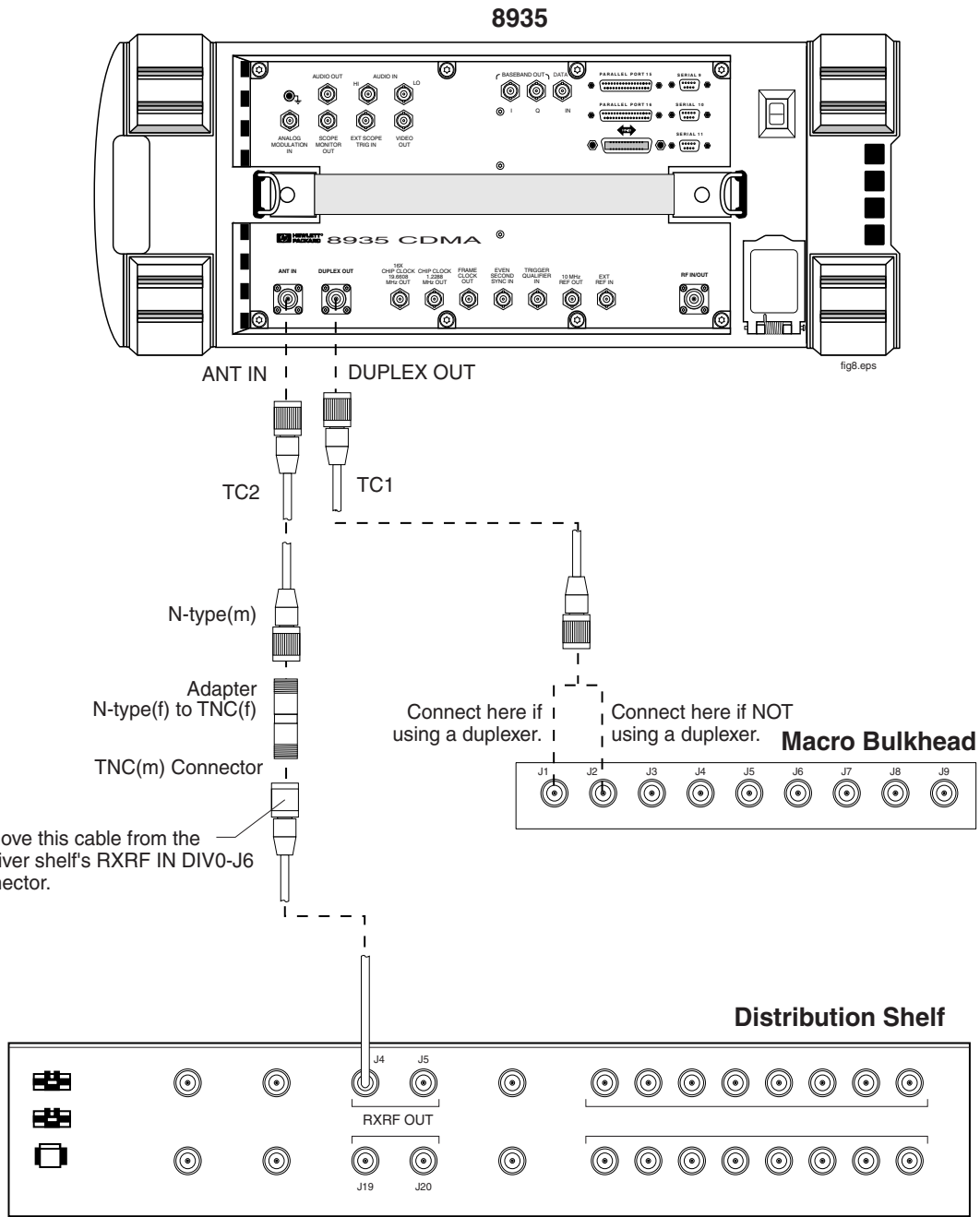


Figure 3-3 CDMA Macro Base Station TX Connection Diagram

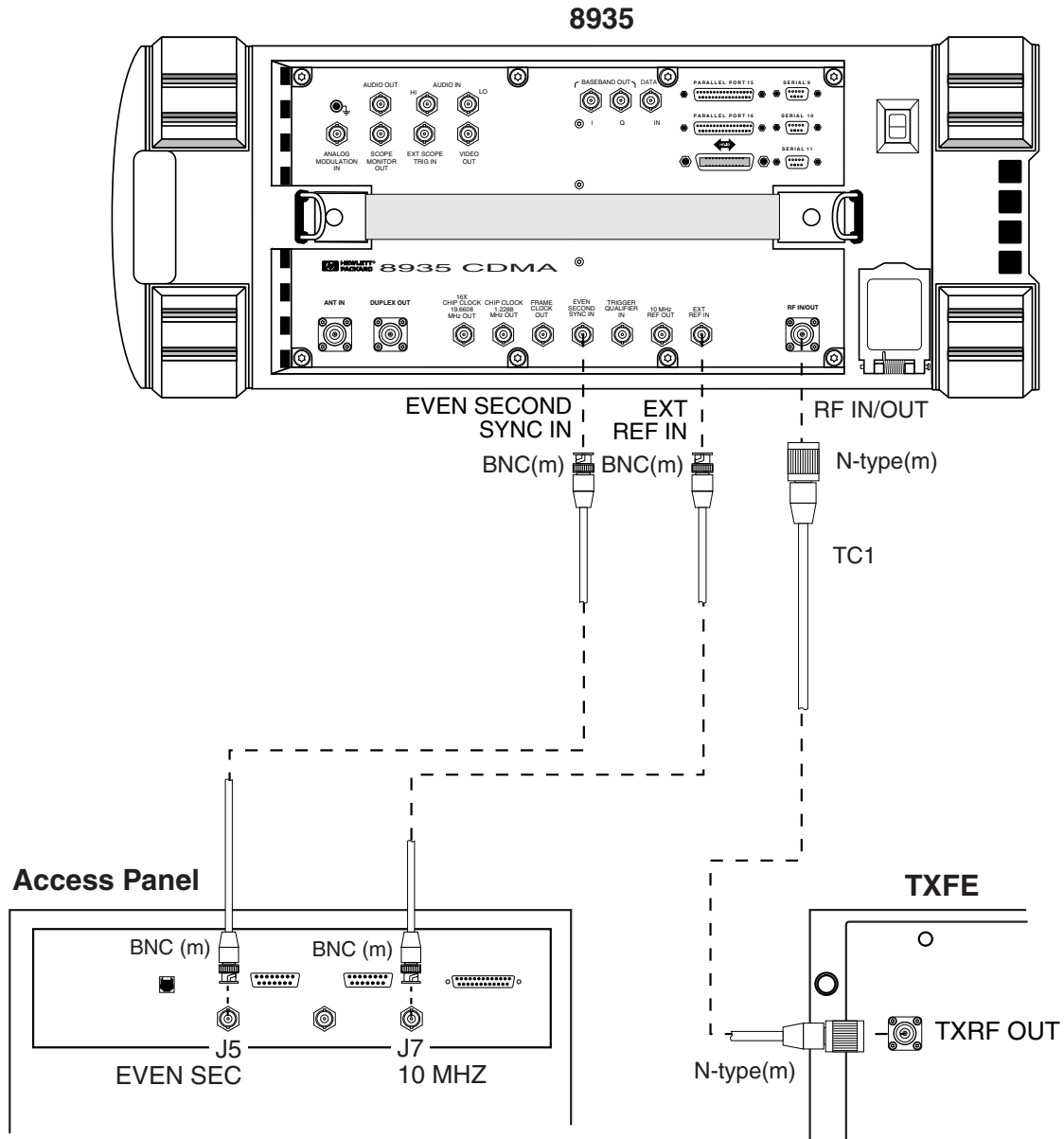


fig 9.eps

Figure 3-4 CDMA C800 Base Station RX0 Receive Path Connection Diagram

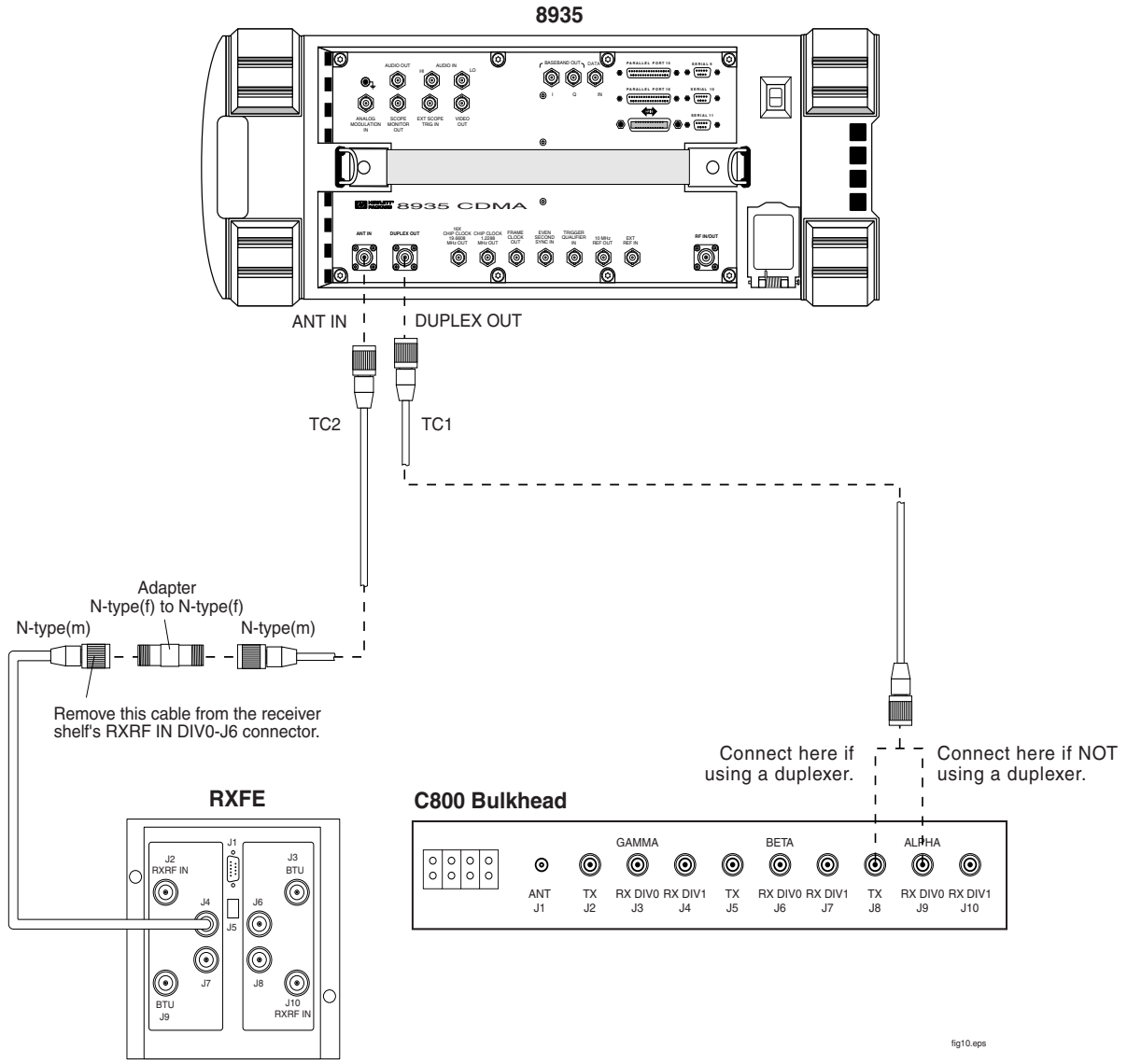


Figure 3-5 CDMA C800 Base Station TX Connection Diagram

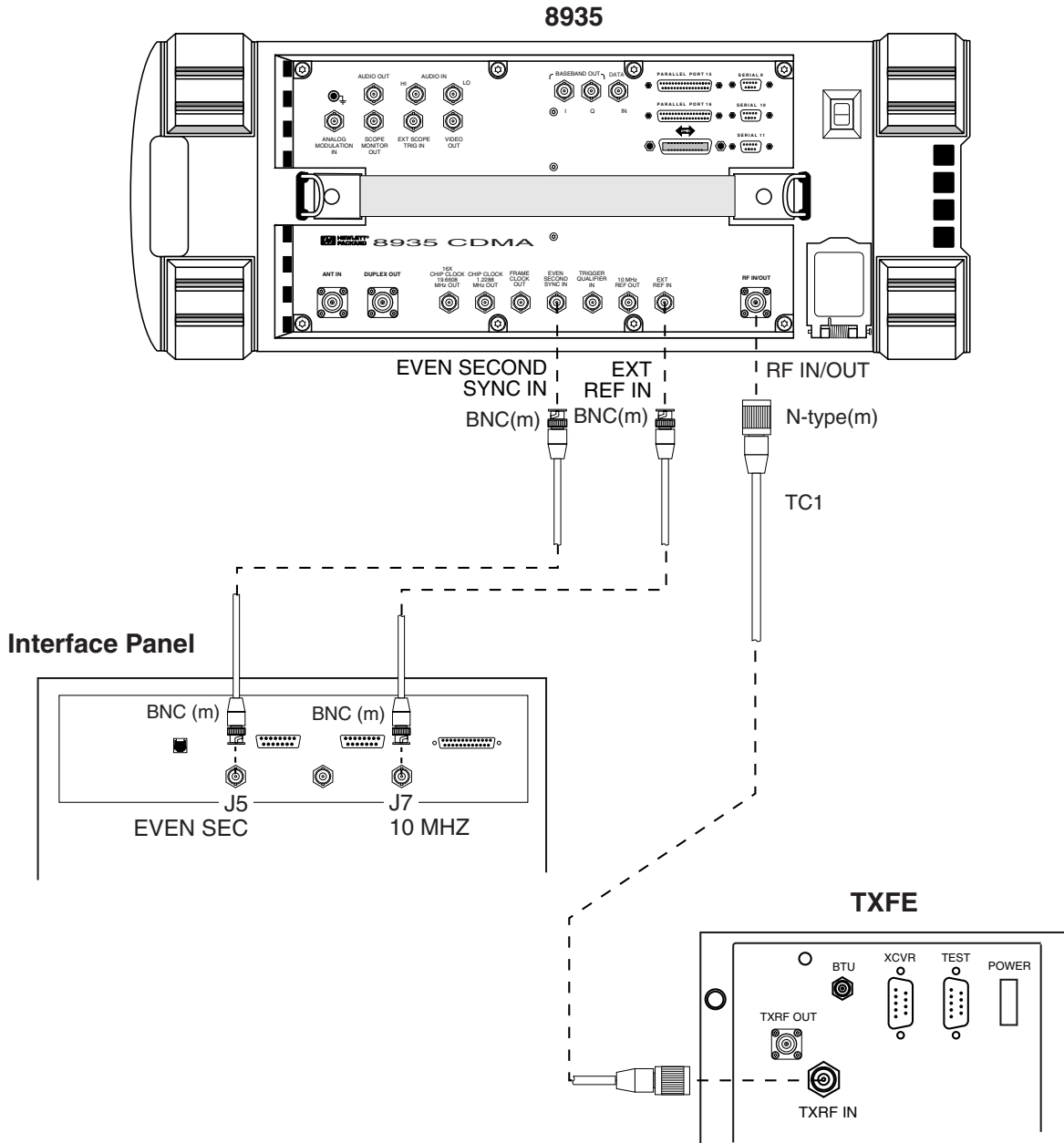


fig11.eps

Figure 3-6 CDMA FCP800 Base Station RX0 Receive Path Connection Diagram

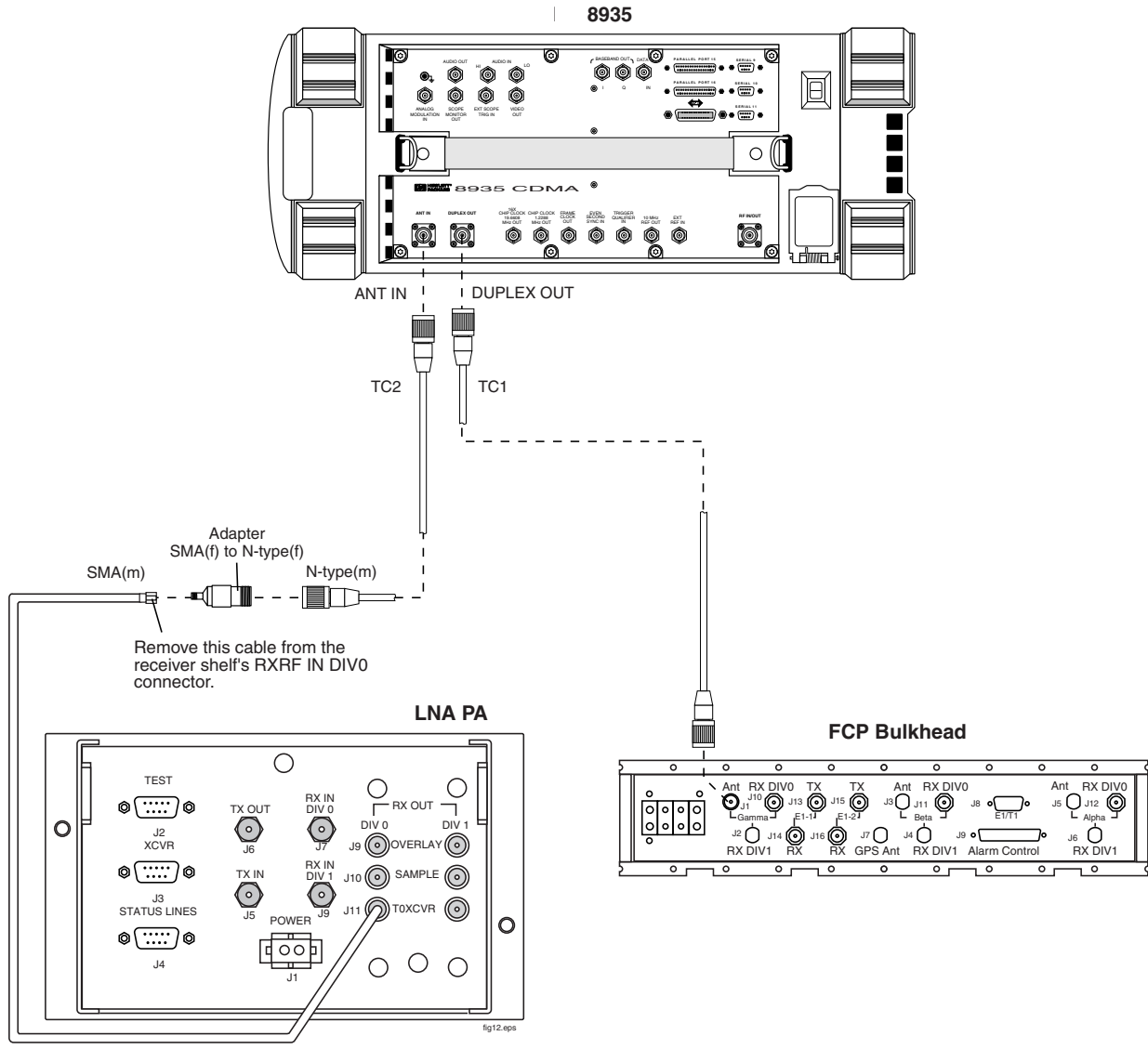


Figure 3-8 CDMA 1900-MHz Base Station RX0 Receive Path Connection Diagram

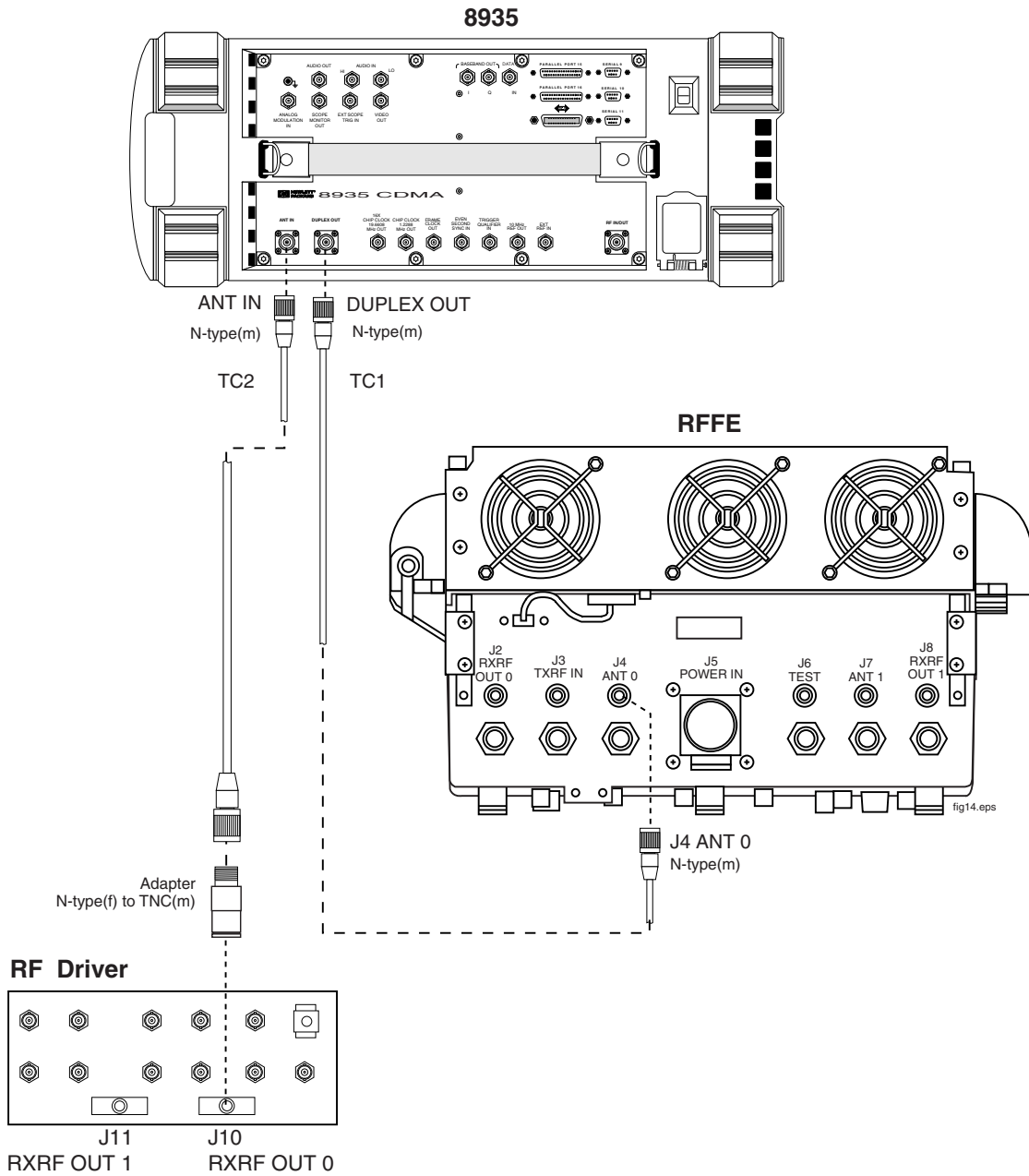
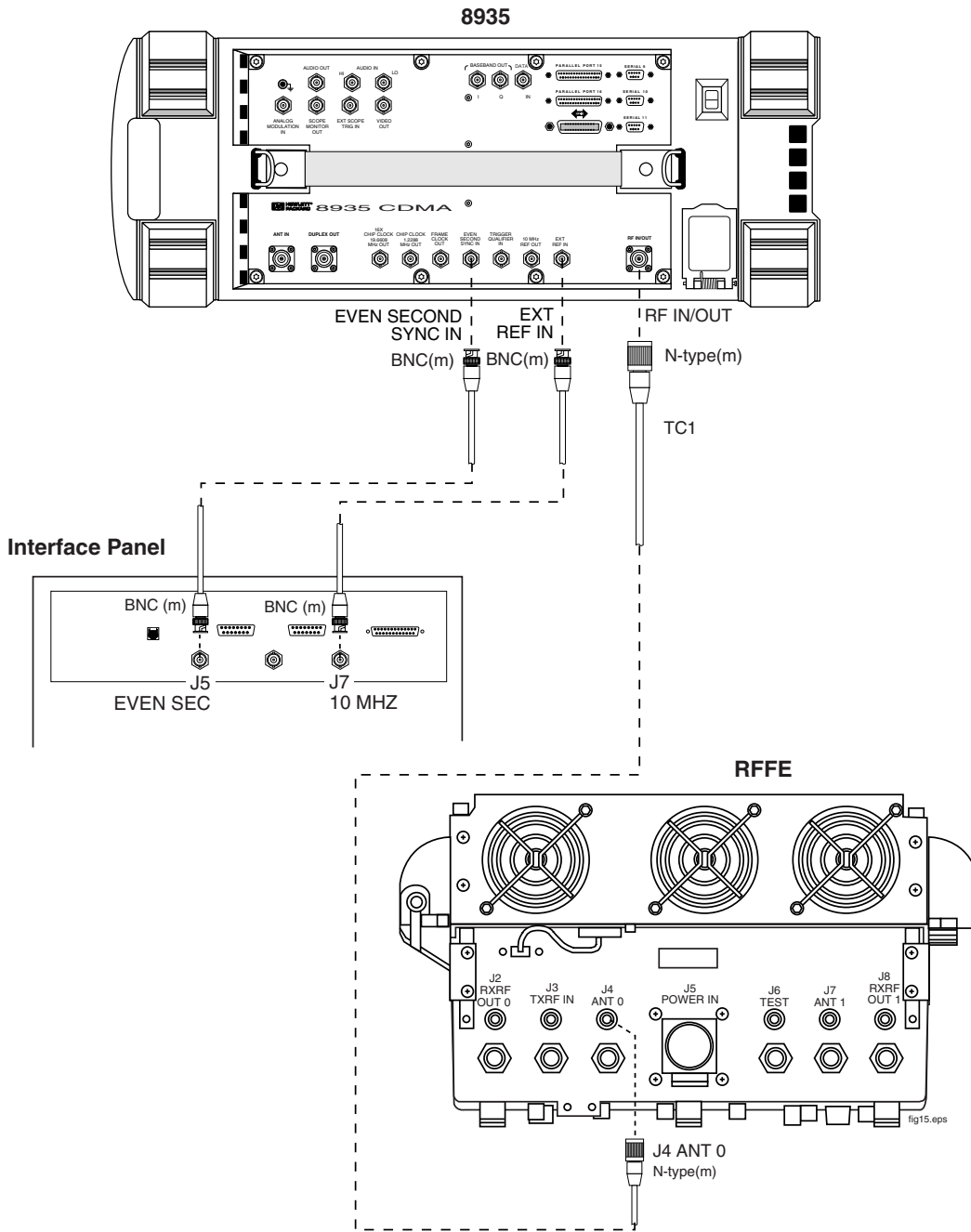


Figure 3-9 CDMA 1900-MHz Base Station TX Connection Diagram



Connections

PC and Printer Connections

This section provides information on personal computer (PC) and printer connections for data collecting and recording.

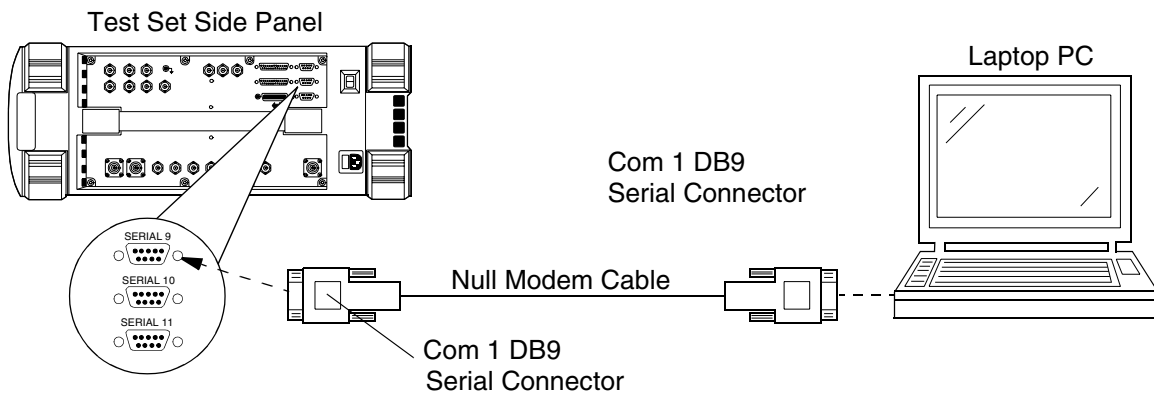
PC

NOTE

The Test Software includes the capability to transfer test results to a PC. This may be done quickly and easily by running the BTS Laptop Utility program on the PC to save the information.

Connect the Test Set SERIAL 9 port to the PC serial port using a DB9-to-DB9 null modem cable (see [Figure 3-10](#)).

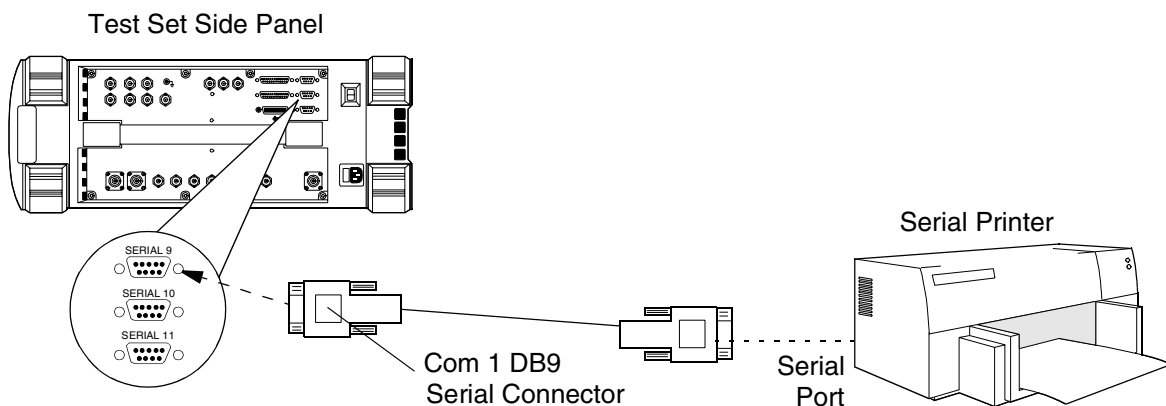
Figure 3-10 Test Set to PC Serial Connection



Serial Printer

Connect the Test Set SERIAL 9 port to the serial printer using a standard serial (DB9-to-DB9) cable (see [Figure 3-11](#)).

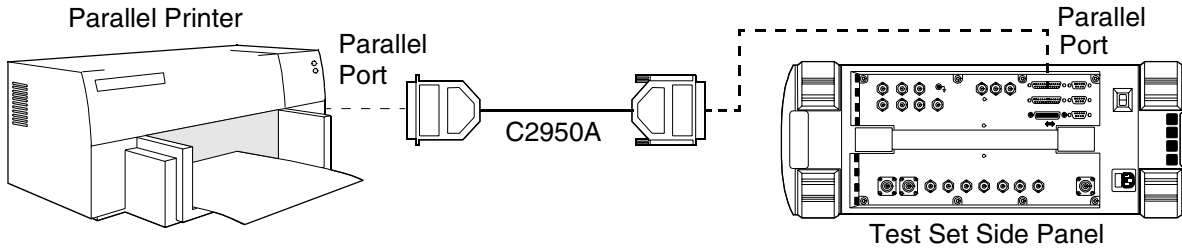
Figure 3-11 Test Set to Serial Printer Connection



Parallel Printer

Connect the Test Set PARALLEL 15 port to the printer using a standard parallel printer cable (see [Figure 3-12](#)).

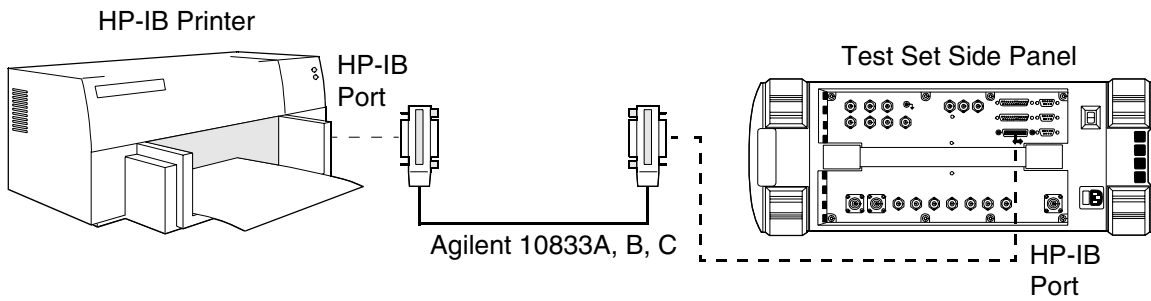
Figure 3-12 Test Set to Parallel Printer Connection



HP-IB Printer

Connect the Test Set HP-IB port to the printer using a standard HP-IB printer cable (see [Figure 3-13](#)).

Figure 3-13 Test Set to HP-IB Printer Connection



4 Reference

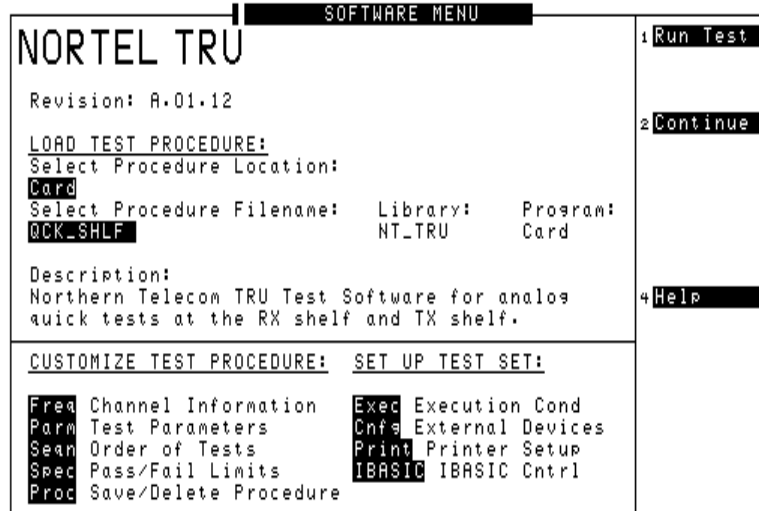
This chapter provides detailed descriptions of the general features and functions of the Test Software. Topics are arranged alphabetically for quick and easy reference.

Customizing Test Procedures

Customizing test procedures is accomplished from the SOFTWARE MENU screen (see Figure 4-1).

Figure 4-1 SOFTWARE MENU Screen

The fields listed under **CUSTOMIZE TEST PROCEDURE:** are used to customize the Test Software for various test requirements.

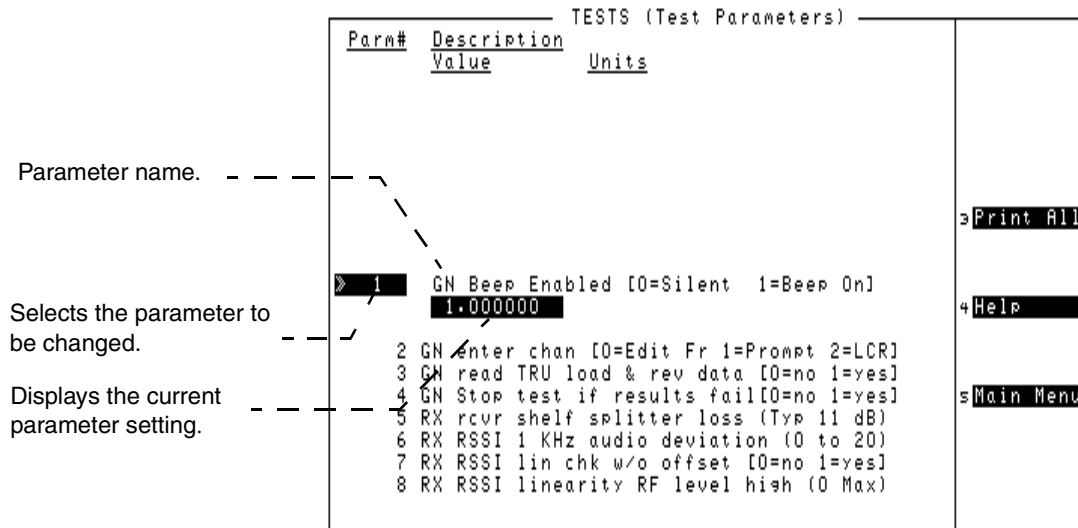


Test Procedures have been designed so that changes may be made easily from the Test Set front panel. For example, tests may be inserted or deleted and, after running the tests, you may change the pass/fail limits or test different channels. You may store a customized procedure on an SRAM card so that you may use it in the future (see “Saving/Deleting Procedures to/from a Card” on page 57).

Changing Test Parameters

Changing test parameters is accomplished from the TESTS (Test Parameters) screen (see [Figure 4-2](#)).

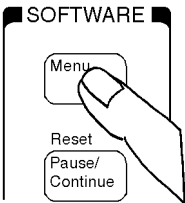








Figure 4-2 TESTS (Test Parameters) Screen



The Software uses parameters to optimize the test environment and conditions for the testing application. The default test parameters were determined by examining test requirements and specifications from the equipment manufacturer. The Test Software comes with default settings for all test parameters.

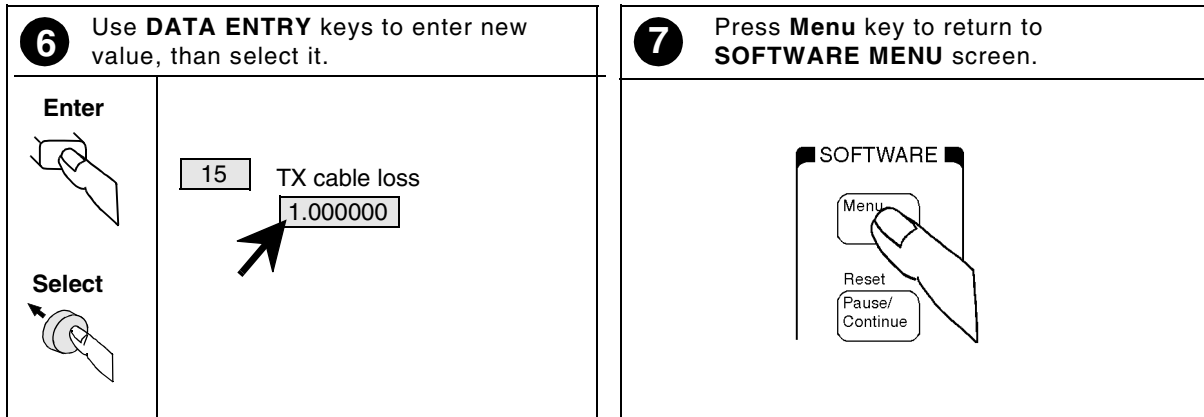
The procedure shown in [Figure 4-3](#) and [Figure 4-4](#) describes the process for changing test parameters through the TESTS (Test Parameters) screen to optimize testing conditions. For information on saving customized test parameters, see [“Saving/Deleting Procedures to/from a Card”](#) on page 57.

Figure 4-3 Changing Test Parameters

<p>1 Press Menu key to display SOFTWARE MENU screen.</p> <p>If IBASIC is running, press Shift, Pause/Continue before pressing Menu.</p> 	<p>2 Scroll to Parm Test Parameters and select it.</p> <p>Position</p>  <p>Select</p>  <table border="1" data-bbox="1003 415 1344 562"> <tr><td>Freq</td><td>Channel Information</td></tr> <tr><td>Parm</td><td>Test Parameters</td></tr> <tr><td>Seqn</td><td>Order of Tests</td></tr> <tr><td>Spec</td><td>Pass Fail Limits</td></tr> <tr><td>Proc</td><td>Save/Delete Procedure</td></tr> </table>	Freq	Channel Information	Parm	Test Parameters	Seqn	Order of Tests	Spec	Pass Fail Limits	Proc	Save/Delete Procedure
Freq	Channel Information										
Parm	Test Parameters										
Seqn	Order of Tests										
Spec	Pass Fail Limits										
Proc	Save/Delete Procedure										
<p>Test Software displays TESTS (Test Parameters) screen.</p>	<p>3 Scroll to Parm # and select it.</p> <p>(Entries on the display might be different.)</p> <p>Position</p>  <p>Select</p>  <table border="1" data-bbox="979 905 1287 978"> <tr><td>1</td><td>RT audio test to</td></tr> <tr><td></td><td>0.00000</td></tr> </table>	1	RT audio test to		0.00000						
1	RT audio test to										
	0.00000										
<p>4 Scroll to Parm # to be changed and select it.</p> <p>Scroll</p>  <p>Select</p>  <p>(This parameter number and description are examples.)</p> <table border="1" data-bbox="391 1346 638 1381"> <tr><td>15</td><td>TX cable loss</td></tr> </table>	15	TX cable loss	<p>5 Scroll to Value and select it.</p> <p>Position</p>  <p>Select</p>  <table border="1" data-bbox="1003 1346 1247 1419"> <tr><td>15</td><td>TX cable loss</td></tr> <tr><td></td><td>0.000000</td></tr> </table>	15	TX cable loss		0.000000				
15	TX cable loss										
15	TX cable loss										
	0.000000										

Continue on next page.

Figure 4-4 Changing Test Parameters (continued)



Changing Pass/Fail Limits

Changing pass/fail limits is accomplished from the TESTS (Pass/Fail Limits) screen (see [Figure 4-5](#)).

Figure 4-5 Changing Pass/Fail Limits

The screenshot shows the 'TESTS (Pass/Fail Limits)' screen with the following table and controls:

Spec#	Description	Lower Limit	Upper Limit	Units	Check
1	RT audio deviation	2.600000	3.200000	kHz	Both
2	RX RSSI level @ 0 dBm				
3	RX RSSI level err @ -50 dBm				
4	RX RSSI level err @ -60 dBm				
5	RX RSSI level err @ -70 dBm				
6	RX RSSI level err @ -80 dBm				
7	RX RSSI level err @ -90 dBm				
8	RX RSSI level err @ -100 dBm				

Annotations on the left side of the screen:

- Selects limits for comparison with measured results. Choices includes Upper, Lower, or Both.
- The descriptions for your application might be different than shown here.
- Selects the pass/fail limits to be edited.
- Sets the lower or upper pass/fail limits.

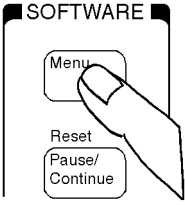


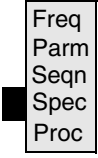


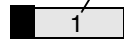


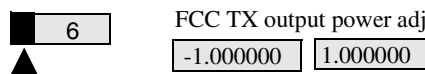


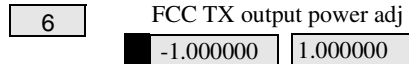
Controls on the right side of the screen:

- Print All
- Help
- Main Menu

Pass/Fail limits define the values with which a measurement result is compared to determine if the system under test meets specified standards. Default values are set in the Test Software. These default values may be changed to meet the requirements of the particular application.













The procedure shown in [Figure 4-6](#) and [Figure 4-7](#) describes the process for changing pass/fail limits through the TESTS (Pass/Fail Limits) screen to optimize testing conditions. For information on saving customized pass/fail limits, see [“Saving/Deleting Procedures to/from a Card”](#) on page 57.

Figure 4-6 Changing Pass/Fail Limits

<p>1 Press Menu key to display SOFTWARE MENU screen.</p> <p>If IBASIC is running, press Shift, Pause/Continue before pressing Menu.</p> 	<p>2 Position cursor at Spec Pass/Fail Limits and select it.</p> <p>Position</p>  <p>Select</p>   <p>Channel Information Test Parameters Order of Tests Spec Pass/Fail Limits Save/Delete Procedure</p>
<p>Test Software displays TESTS (Pass/Fail Limits) screen.</p>	<p>3 Scroll to Spec # field and select it.</p> <p>Position</p>  <p>Select</p>  <p>(Disregard this number.)</p> 
<p>4 Scroll to desired Spec # and select it.</p> <p>Scroll</p>  <p>Select</p>  <p>(This Spec # is an example.)</p> 	<p>5 Scroll to Lower Limit and select it.</p> <p>Position</p>  <p>Select</p>  

Continue on next page.

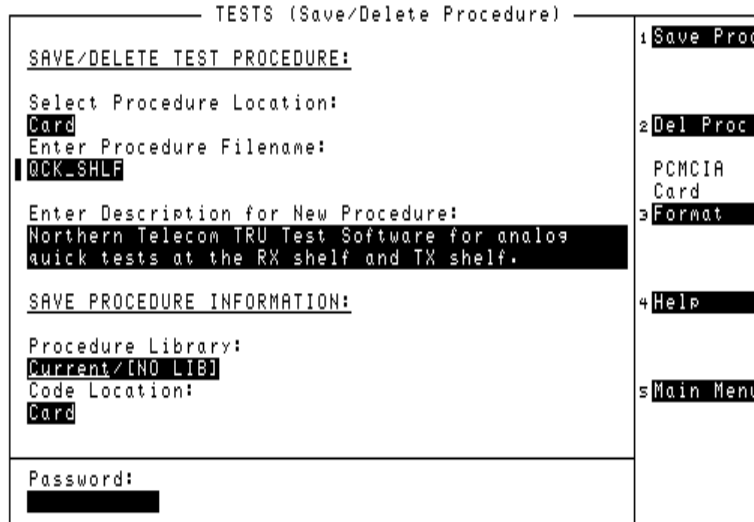
Figure 4-7 Changing Pass/Fail Limits (continued)

<p>6 Use DATA ENTRY keys to enter new value, then select it.</p> <p>Enter </p> <p>Select </p> <p>6 FCC TX output power a <input type="text" value="-0.500000"/> <input type="text" value="1.000000"/></p> <p>(Enter the desired value.)</p>	<p>7 Position cursor at Upper Limit field and select it.</p> <p>Position </p> <p>Select </p> <p>CC TX output power adjustment <input type="text" value=".500000"/> <input checked="" type="text" value="1.000000"/> dB</p>
<p>8 Use DATA ENTRY keys to enter new value, then select it.</p> <p>Enter </p> <p>Select </p> <p>CC TX output power adjustment <input type="text" value=".500000"/> <input checked="" type="text" value="0.500000"/> dB</p> <p>(Enter the desired value.)</p>	<p>9 Position cursor at Check field and select it.</p> <p>Position </p> <p>Select </p> <p><input checked="" type="text" value="Both"/></p>
<p>10 Position cursor for which limits should apply to testing and select it.</p> <p>Position </p> <p>Select </p> <p>Choices: Upper Lower <input checked="" type="checkbox"/> Both None</p>	<p>11 Press Menu key to return to SOFTWARE MENU screen.</p> <p>Position </p> <p>Select </p> <p>SOFTWARE MENU <input type="text" value="Menu"/> <input type="text" value="Reset"/> <input type="text" value="Pause/Continue"/></p>

Saving/Deleting Procedures to/from a Card

Saving procedures to an SRAM card and deleting procedures from a card are accomplished from the TESTS (Save/Delete Procedure) screen (see [Figure 4-8](#)).

Figure 4-8 TESTS (Save/Delete Procedure) Screen



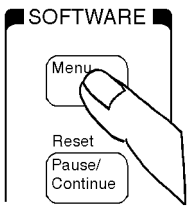

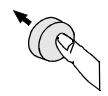

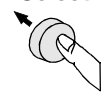
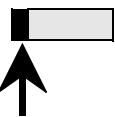
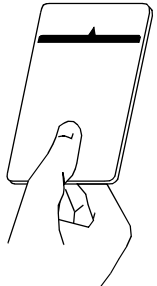


A test procedure is a collection of channel information, test parameters, testing order, and pass/fail limits saved in a file. This file might be one of the default procedures that is supplied on the Test Software PC card, or it might be an application specific procedure that customizes the Test Software to a specific application. Ordinarily, custom procedures are saved on an SRAM card.

When you save a custom procedure, it consists of channel information, test parameters, pass/fail limits, and testing order, plus a library that contains the names of all test parameters, pass/fail limits, and tests that are resident in the Test Software. The library file comes from the Test Software and cannot be modified. The library file is saved automatically on the SRAM card that is used to store the new test procedure.

The procedure shown in [Figure 4-9](#), [Figure 4-10](#), and [Figure 4-11](#) describes the process for saving a procedure through the TESTS (Save/Delete Procedure) screen.


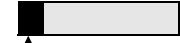
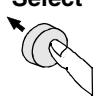

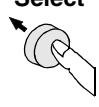


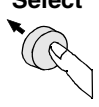

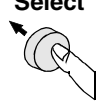

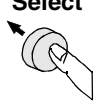

Delete a procedure using the same process, except for step 13. To delete a procedure, select the **Del Proc** field or press the **k2 (Del Proc)** key.

Figure 4-9 Saving or Deleting a Procedure

<p>1 Press Menu key to display SOFTWARE MENU screen.</p> <p>If IBASIC is running, press Shift, Pause/Continue before pressing Menu.</p> 	<p>2 Scroll to Proc Save/Delete Procedure and select it.</p> <p>Position</p>  <p>Select</p>  <table border="1" data-bbox="1031 420 1396 588"> <tr><td>Freq</td><td>Channel Information</td></tr> <tr><td>Parm</td><td>Test Parameters</td></tr> <tr><td>Seqn</td><td>Order of Tests</td></tr> <tr><td>Spec</td><td>Pass Fall Limits</td></tr> <tr><td>Proc</td><td>Save/Delete Procedure</td></tr> </table>	Freq	Channel Information	Parm	Test Parameters	Seqn	Order of Tests	Spec	Pass Fall Limits	Proc	Save/Delete Procedure
Freq	Channel Information										
Parm	Test Parameters										
Seqn	Order of Tests										
Spec	Pass Fall Limits										
Proc	Save/Delete Procedure										
<p>Test Software displays TESTS (Save/Delete Procedure) screen.</p>	<p>3 Scroll to Select Procedure Location and select it.</p> <p>Position</p>  <p>Select</p>  <p>Select Procedure Location:</p> 										
<p>4 Insert initialized SRAM card.</p> <p>To initialize an SRAM card, press the k3 (Format) key and follow the prompts on the TESTS (Save/Delete Procedure) screen.</p> 	<p>5 Position cursor at Card and select it.</p> <p>Position</p>  <p>Select</p>  <table border="1" data-bbox="1128 1281 1274 1428"> <tr><td>Choices:</td></tr> <tr><td>■ Card</td></tr> <tr><td>RAM</td></tr> </table> <p>(You may also save procedures to an internal RAM disk.)</p>	Choices:	■ Card	RAM							
Choices:											
■ Card											
RAM											


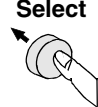

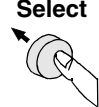

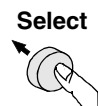
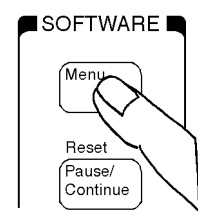
Continue on next page.

Figure 4-10 Saving or Deleting a Procedure (continued)

<p>6 Scroll to Enter Procedure Filename and select it.</p>	<p>7 Select characters to name Procedure, then select Done.</p>										
<p>Position </p> <p>Enter Procedure Filename:</p>  <p>Select </p>	<p>Position </p> <p>→</p> <table border="1" data-bbox="1096 388 1247 682"> <tr><td>Choices:</td></tr> <tr><td>Done</td></tr> <tr><td>Position</td></tr> <tr><td>Over/Ins</td></tr> <tr><td>Delete</td></tr> <tr><td>Del End</td></tr> <tr><td>Bk space</td></tr> <tr><td>■ A</td></tr> <tr><td>B</td></tr> <tr><td>C</td></tr> </table> <p>Select </p> <p>→</p>	Choices:	Done	Position	Over/Ins	Delete	Del End	Bk space	■ A	B	C
Choices:											
Done											
Position											
Over/Ins											
Delete											
Del End											
Bk space											
■ A											
B											
C											
<p>8 Scroll to Enter Description for New Procedure: and select it.</p>	<p>9 Select characters for description, then select Done.</p>										
<p>Position </p> <p>Enter Description for</p>  <p>Select </p>	<p>Position </p> <p>→</p> <table border="1" data-bbox="1096 814 1247 1108"> <tr><td>Choices:</td></tr> <tr><td>Done</td></tr> <tr><td>Position</td></tr> <tr><td>Over/Ins</td></tr> <tr><td>Delete</td></tr> <tr><td>Del End</td></tr> <tr><td>Bk space</td></tr> <tr><td>■ A</td></tr> <tr><td>B</td></tr> <tr><td>C</td></tr> </table> <p>Select </p> <p>→</p>	Choices:	Done	Position	Over/Ins	Delete	Del End	Bk space	■ A	B	C
Choices:											
Done											
Position											
Over/Ins											
Delete											
Del End											
Bk space											
■ A											
B											
C											
<p>10 Scroll to Procedure Library: and select Current.</p>	<p>11 Scroll to Code Location: and select it.</p>										
<p>Position </p> <p>Procedure Library:</p> <table border="1" data-bbox="406 1270 649 1312"> <tr><td><u>Current</u> / [NO LIB]</td></tr> </table> <p>↑</p> <p>(The underline indicates which option is selected. Pressing the knob changes the selection.)</p> <p>Select </p>	<u>Current</u> / [NO LIB]	<p>Position </p> <p>↑</p> <table border="1" data-bbox="966 1291 1071 1333"> <tr><td>Card</td></tr> </table>	Card								
<u>Current</u> / [NO LIB]											
Card											

Continue on next page.

Figure 4-11 Saving or Deleting a Procedure (continued)

<p>12 Scroll to Card and select it.</p> <div style="display: flex; align-items: center; gap: 20px;"> <div style="text-align: center;"> <p>Position</p>  <p>Select</p>  </div> <div style="border: 1px solid black; padding: 5px;"> <p>Choices:</p> <ul style="list-style-type: none"> ■ Card ROM RAM </div> </div>	<p>13a Scroll to Save Proc and select it or press k1.</p> <div style="display: flex; align-items: center; gap: 20px;"> <div style="text-align: center;"> <p>Position</p>  <p>Select</p>  </div> <div style="border: 1px solid black; padding: 5px;"> <ul style="list-style-type: none"> ■ Save Proc 2 Del Proc 3 Init Card 4 Help 5 Main Menu </div> </div>
<p>13b Scroll to Del Proc and select it or press k1.</p> <div style="display: flex; align-items: center; gap: 20px;"> <div style="text-align: center;"> <p>Position</p>  <p>Select</p>  </div> <div style="border: 1px solid black; padding: 5px;"> <ul style="list-style-type: none"> 1 Save Proc ■ Del Proc 3 Init Card 4 Help 5 Main Menu </div> </div>	<p>14 Press Menu key to return to SOFTWARE MENU screen.</p> <div style="text-align: center; margin-top: 20px;">  </div>
<p>15 Run saved procedure as follows:</p> <ol style="list-style-type: none"> 1) Insert the SRAM Card with the saved procedure. 2) On the SOFTWARE MENU screen, a) select Select Procedure Location: then select Card, b) select Select Procedure Filename:, then select the saved file name. 3) Remove the SRAM Card, then insert the original Test Software PC card. 4) Press Run Test. <p>The original card contains the full program required to run the procedure.</p>	

Saving/Deleting Procedures to/from Internal RAM

Saving procedures to Test Set internal RAM and deleting procedures from internal RAM are accomplished from the TESTS (Save/Delete Procedure) screen (see [Figure 4-8](#)) much as described in the previous section, [Saving/Deleting Procedures to/from a Card](#), and shown in [Figure 4-9](#), [Figure 4-10](#), and [Figure 4-11](#), except for the following:

- In [Figure 4-9](#), step 4, initialize the RAM disk as outlined in “[Initializing a RAM Disk](#)” on page 77.
- In [Figure 4-9](#), step 5, select **RAM** instead of **Card**.
- In [Figure 4-11](#), step 15, sub-step 1 is not applicable.
- In step 15, sub-step 2, select **RAM** instead of **Card**.
- In step 15, sub-step 3, if the Test Software PC card is not inserted in the Test Set front panel card slot, do so.

Handling Test Results

It is often desirable to record test results for future reference or evaluation. The Test Software provides the capability to save test results to a variety of destination devices. These are:

- A personal computer (PC) (ordinarily a laptop PC)
- An SRAM card
- A serial printer
- A parallel printer
- An HP-IB printer

The capability to save test results remains on until you turn it off.

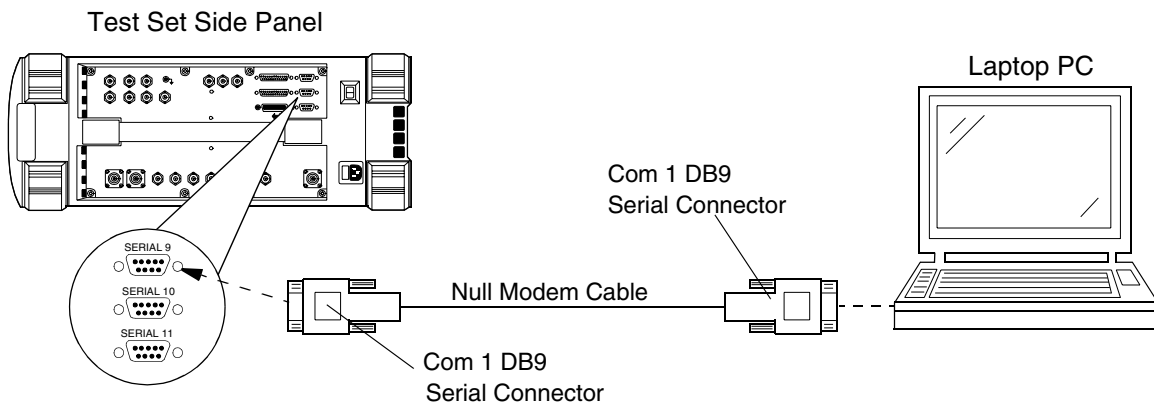
The following printers are supported by the Test Software:

- HP ThinkJet printer
- HP QuietJet printer
- HP PaintJet printer
- HP LaserJet printer
- HP DeskJet printer
- Epson FX-80
- Epson LQ-850

Sending Test Results to a PC Using the BTS Laptop Utility

Test results may be supplied directly to a PC through the Test Set SERIAL 9 port (see [Figure 4-12](#)) using a PC running the BTS Laptop Utility program.

Figure 4-12 Test Set to PC Serial Connection



The requirements to save test results to a PC are as follows:

- The Test Set SERIAL 9 port must be connected to the PC using a null modem cable.
- The configured BTS Laptop Utility must be running on the PC.
- The **Use BTS Laptop Utility** field in the Test Results/Laptop Util/Printer/Serial Setup screen must be set to **Yes**.
- The Test Set SERIAL 9 port communication parameters must be configured to match the communication parameters of the PC.

Configuring the PC Terminal Program.

Sending test results to a PC requires starting the BTS Laptop Utility on the PC, then setting the Test Software to use the utility.

Perform the setup as follows:

- Step 1.** From the PC, start the BTS Laptop Utility program (see [Figure 4-13](#)).

Figure 4-13 Starting the BTS Laptop Utility Program



- Step 2.** On the PC screen, click on the **TR** button (see [Figure 4-14](#)) to display the **Test Results** window, in which the test results will be displayed.

Figure 4-14 Selecting the Test Results Window



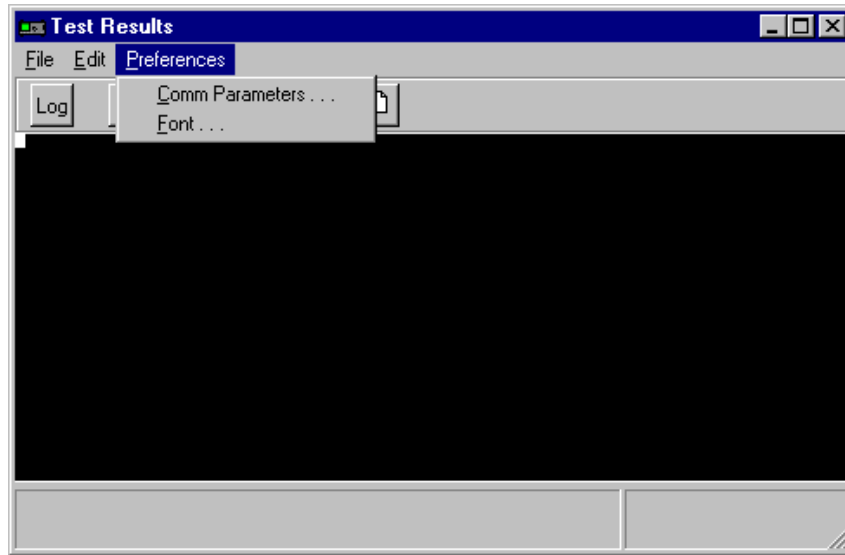
Test Results button.

NOTE

The Test Software does not use communication with the Switch for testing purposes. Thus, you might find it advantageous to turn off the **SW** button in the BTS Laptop Utility tool bar. To do this, select the File Properties window in the BTS Utility, then add **-NoSwitch** at the end of the Shortcut Tab in the Target field.

- Step 3.** On the PC screen, click on the **Preferences** field, then click on the **Comm Parameters** field (see [Figure 4-15](#)) to display the Comm Port Setup screen.

Figure 4-15 Selecting the Comm Port Setup Screen



Step 4. On the Comm Port Screen, set the Test Set port to the serial port to which the null modem cable is connected on the Test Set (SERIAL 9).

Step 5. On the Comm Port Setup screen, set the Test Set baud rate to match the baud rate of the PC.

NOTE

If the rate is higher than 19200 baud, the Test Set SERIAL 9 port flow control must be set to **Hardware**.

Step 6. On the Comm Port Setup screen, set the Switch Port to **No Port**.

NOTE

The Test Software does not use communication with the Switch for testing. If you have already set the Shortcut Tab as shown in the note in step 2, step 6 will not be required. The **No Port** selection will not appear.

Step 7. On the Comm Port screen, click on the **OK** button.

Sending the Results

To send test results to a PC, you must enable sending test results within the Test Software. Do this as follows:

- Connect the PC to the Test Set SERIAL 9 port using a null modem cable.
- On the Test Set, press the **Menu** key. The Test Set will display the SOFTWARE MENU screen.
- On the Test Set, press the **k1 (Run Test)** key to start the Test Software. The Test Software will display the Configuration Menu screen.
- On the Test Set, select the **Test Results/Laptop Util/Printer/Serial Setup** field. The Test Software will display the Test Results/Laptop Util/Printer/Serial Setup screen.
- On the Test Set, select the **BTS Laptop Utility** field so that the choice field toggles to **Yes**.

NOTE

If the Test Software does not change the field to **Yes**, see the BTS Laptop Utility help tool for hardware flow control. Also, make certain that you have completed all steps of this procedure correctly.

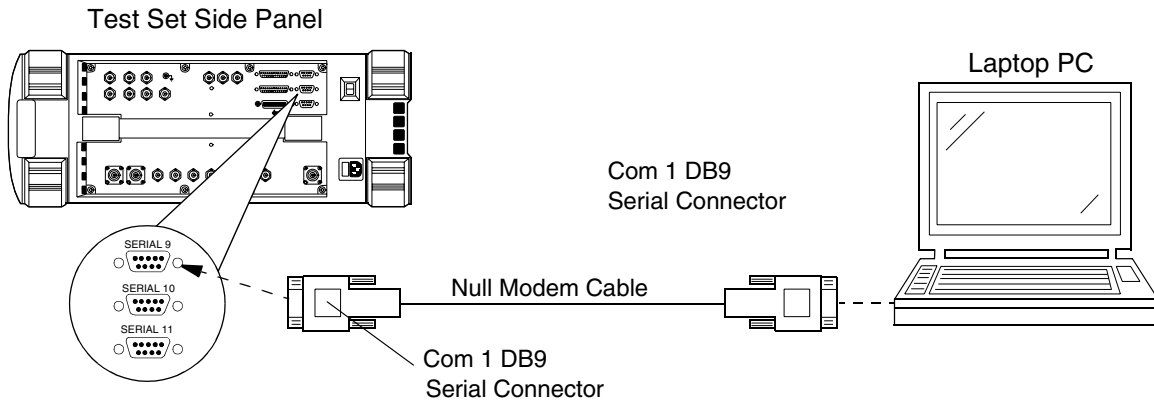
- On the PC, start the BTS Laptop Utility program.
- On the Test Set, select the **Serial 9 Port Settings** field. Verify that the communication parameters match those of the BTS Laptop Utility program.

The Test Set will send test results to the PC using the BTS Laptop Utility until you set the **Use BTS Laptop Utility** field to **No** in the Test Results/Laptop Util/Printer/Serial Setup screen.

Sending Test Results to a PC

Test results may be supplied directly to a PC (with a communication program) through the Test Set SERIAL 9 port (see [Figure 4-16](#)). A variety of devices may be used to receive the data. An HP Palmtop computer, PC, or terminal may be used. A terminal emulator may be used to write the test results directly to a file. Examples of terminal emulator programs are HyperTerminal© and ProComm.

Figure 4-16 Test Set to PC Serial Connection



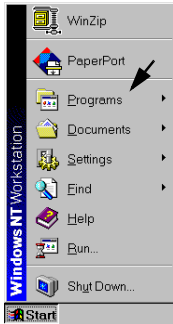
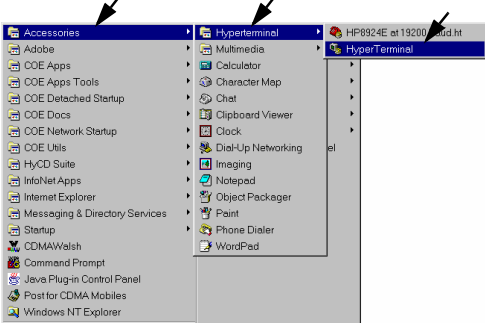
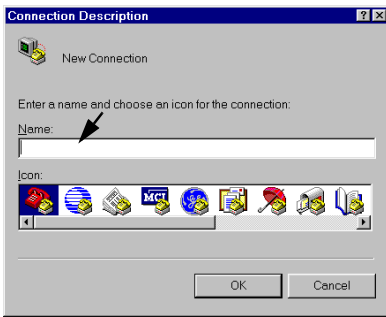
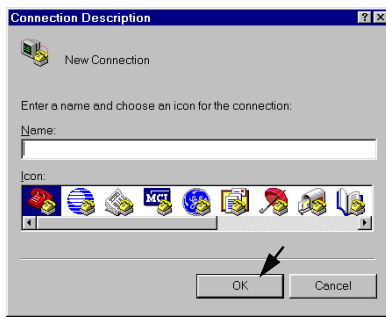
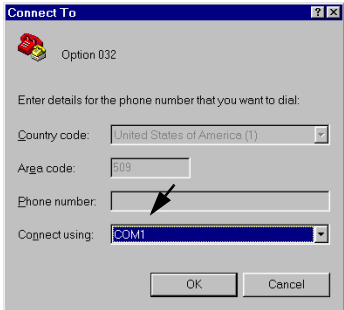
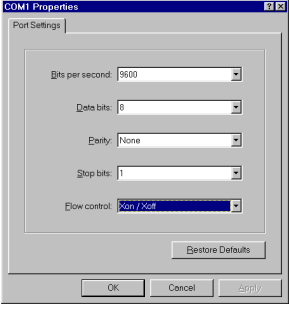
The requirements to save test results to a PC are as follows:

- The Test Set SERIAL 9 port must be connected to the PC.
- A configured terminal program must be running on the PC.
- The Send Test Results to Serial 9 function must be activated in the Software.
- The Test Set SERIAL 9 port communication parameters must be configured to match the communication parameters of the PC.

Configuring the PC Terminal Program

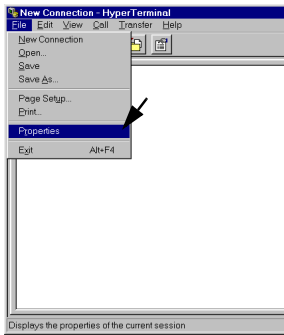
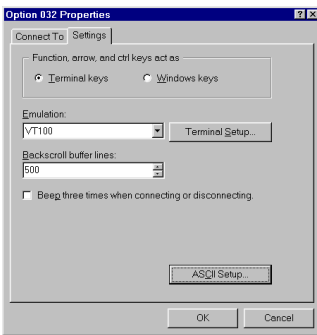
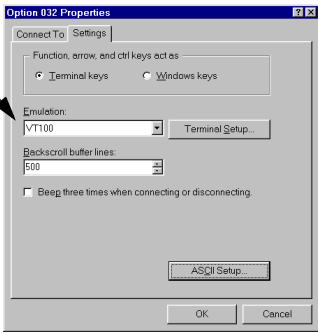
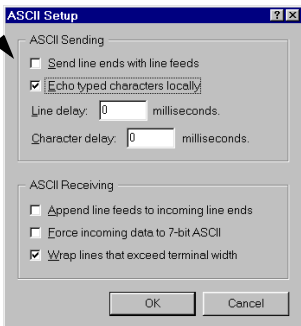
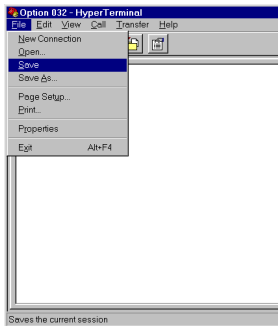
Sending test results to a PC requires that a configured terminal emulator be running while sending test results is enabled. See [Figure 4-17](#) and [Figure 4-18](#) for the detailed procedures required to configure a terminal program for saving test results to a PC.

Figure 4-17 Configuring a Terminal Program for Sending Test Results to a PC

<p>1 From Start on the PC, select Programs.</p> 	<p>2 From Programs select, Accessories, Hyperterminal, Hyperterminal.</p> 
<p>3 In the Connection Description menu, enter a Name in the name field.</p> 	<p>4 Select an icon, then press OK</p> 
<p>5 In the Connect To menu, select COM1 or COM2, then select OK.</p> 	<p>6 When the Properties menu opens, enter the port settings and select OK.</p> <p>Default Settings: Baud: 9600 Data bits: 8 Parity: None Stop bits: 1 Flow Control: Xon/Xoff</p> 

Continue on next page.

Figure 4-18 Configuring a Terminal Program for Sending Test Results to a PC (continued)

<p>7 After port settings are entered, select File then Properties.</p>  <p>Displays the properties of the current session</p>	<p>8 From the Properties menu, select the Settings' tab.</p>  <p>OK Cancel</p>
<p>9 On the Settings menu, enter VT 100 in the Emulation field, then select OK.</p>  <p>OK Cancel</p>	<p>10 On the ASCII Setup menu, check Echo typed chara...., then select OK.</p>  <p>OK Cancel</p>
<p>11 Select OK to close the Properties menu, then save the file for future use.</p>  <p>Saves the current session</p>	<p>After configuring the personal computer to receive the measured data, you must turn on data collection in the Test Set and verify that the Serial Port 9 Settings match those of the terminal emulator.</p>

Sending the Results

To send test results to a PC, you must enable sending test results within the Test Software. Do this as follows:

- Press the **Menu** key. The Test Set will display the SOFTWARE MENU screen.
- Press the **k1 (Run Test)** key to start the Test Software. The Test Software will display the Configuration Menu screen.
- Select the **Test Results/Laptop Util/Printer/Serial Setup** field. The Test Software will display the Test Results/Laptop Util/Printer/Serial Setup screen.
- Verify that the **Use BTS Laptop Utility** field is toggled to **No**.
- Select the **Send Test Results to** field, then select **Serial 9** from the **Choices:** list.
- Start the terminal program.
- Select the **Serial 9 Port Settings** field. Verify that the communication parameters match those of the terminal program.

NOTE

When you have configured the Test Set to send the data to a PC, you must remember to activate the communication package and specify a file in which to save the data. The Test Set will not issue an error message if the PC communication application is not running or configured properly.

The Test Software will send test results to the PC until you turn off the **Send Test Results to** field in the Test Results/Laptop Util/Printer/Serial Setup screen.

Sending Test Results to an SRAM Card

To send test results to an SRAM card, you must enable the Sending Test Results to a PC Card function within the Test Software. The Test Software will create test result files on the SRAM card automatically, based on the name that you enter at the start of testing. The Test Software will append “.txt” to the file name so that the files will be recognized on the SRAM card.

NOTE

Do not remove the card or stop the test during testing operations while sending test results to an SRAM card. If you do so, the files will not be closed properly and the test results will be lost.

Once testing is complete and the test results are in files on the SRAM card, perform the procedure outlined in [“Retrieving Data from an SRAM Card” on page 70](#) to transfer the data to a PC or printer.

NOTE

Before attempting to send test results to an SRAM card, verify that the card is not write-protected. The write-protect switch should not be set toward the edge of the card.

Send test results to an SRAM card as follows:

- Step 1.** Press the **Menu** key. The Test Set will display the SOFTWARE MENU screen.
- Step 2.** Press the **k1 (Run Test)** key to start the Test Software. The Test Software will display the Configuration Menu screen.
- Step 3.** Select the **Test Results/Laptop Util/Printer/Serial Setup** field. The Test Software will display the Test Results/Laptop Util/Printer/Serial Setup screen.
- Step 4.** Insert an SRAM card into the front panel card slot. If the card is un-initialized, see [“Initializing a PC Card” on page 78](#).
- Step 5.** Select the **Send Test Results to** field, then select **PC Card** from the **Choices:** list. The Test Set will display a message asking for a file name under which to store the test results.
- Step 6.** Enter a name using the characters from the **Choices:** list. Select **Done** when finished.

The Test Set will send test results to the SRAM card until you turn off the **Send Results to** field in the Test Results/Laptop Util/Printer/Serial Setup screen.

When the test is completed, the Test Set will close the file on the SRAM card and will change the **Send Test Results to** field in the Test Results/Laptop Util/Printer/Serial Setup screen from **PC Card** to **Off**. Thus, each time that you run the test and wish to record the results to the SRAM card, you must open the Test Results/Laptop Util/Printer/Serial Setup screen and enter a new file name as outlined above.

Retrieving Data from an SRAM Card

Use the utility program (FILE_XFER), which is included in the Test Set, to transfer data files from the SRAM card to a serial printer, an HP-IB printer, or a PC.

NOTE

Loading and running the utility to perform these procedures will replace any programs and procedures in the Test Set internal RAM. Thus, the Test Software must be reloaded when this procedure is complete. This requires that you have the Test Software PC card with you on-site.

Transferring Data to a Printer Via the SERIAL 9 Port or the HP-IB Port

Transfer data to a printer via the SERIAL 9 port or HP-IB port as follows:

- Step 1.** If the Test Software is running, exit it from the Configuration Menu screen by pressing the **Shift** and **Pause/Continue (Reset)** keys, then the **k5 (Main Menu)** key.
- Step 2.** Make certain that the printer is turned on and set up to print when the data is sent to the Test Set SERIAL 9 port or HP-IB port.
- Step 3.** Press the **Menu** key. The Test Set will display the SOFTWARE MENU screen.
- Step 4.** Select the **Select Procedure Location:** field. The Test Set will display a **Choices:** list containing the following items: **Card**, **ROM**, and **RAM**.
- Step 5.** Select **ROM**. This allows the loading of various utility programs resident in the Test Set.

NOTE

In the following step, the items in the **Choices:** list are as shown on the printing date of this manual. However, this list could change in later versions of the Test Software.

- Step 6.** Select the **Select Procedure Filename:** field. The Test Set will display a **Choices:** list containing the following items: **SERVICE4**, **RFTOOLS**, **IB_UTIL**, **LISTOPTS**, **ST_PLT**, and **DEMO**.
- Step 7.** Select **IB_UTIL**.
- Step 8.** Press the **k1 (Run Test)** key to run the utility program. The Test Set will display the **IB_UTIL** screen.
- Step 9.** Select the **FILE_XFER** field. The Test Set will prompt you to insert the SRAM card that contains the test result files.
- Step 10.** Insert the card and select the **Continue** field. The Test Set will display the file transfer menu.
- Step 11.** If using a serial printer, select the **Output Port** field and press the knob to select **Serial Port, 9600 baud**. This configures the Test Set to send the data via the SERIAL 9 port at 9600 baud.

If using an HP-IB printer, select the **Output Port** field and press the knob to select **HPIB, Addr 7xx**. This configures the Test Set to send the data via the HP-IB port.
- Step 12.** Scroll the cursor down the list of file names to the file that you wish to transfer and press the knob to select it. An asterisk (*) will appear next to the name. You may send more than one file at a time. Scroll to and select any other files that you wish to transfer.

NOTE

All files on the SRAM card are displayed, not just the test result files. If you attempt to transfer files that are not test result data, unexpected results at the printer might occur. Also, transferring code files might result in many pages of code being printed. Look for files with “.txt” appended to the name, which indicates test result files.

- Step 13.** When all files to be transferred have been selected, select the **Start Transfer** field. The data will be sent to the printer via the SERIAL 9 or HP-IB port.
- Step 14.** When printing is complete, you may select other files to transfer or exit the utility program by selecting the **Exit Data-Collection-File-Transfer** field.
- Step 15.** To return to the Test Software again, press the **k1 (Run Test)** key from the SOFTWARE

MENU screen.

Transferring Data to a PC Via the SERIAL 9 Port

Transfer data to a PC via the SERIAL 9 port as follows:

- Step 1.** If the Test Software is running, exit it from the Configuration Menu screen by pressing the **Shift** key, then the **Pause/Continue (Reset)** keys, then the **k5 (Main Menu)** key.
- Step 2.** Connect the Test Set to the PC using the SERIAL 9 port and a null modem cable.
- Step 3.** Load a PC utility program for communicating on the PC serial port such as HyperTerminal.
- Step 4.** Configure the PC program to prepare the PC to receive a text file via the serial port.
- Step 5.** Press the **Menu** key. The Test Set will display the SOFTWARE MENU screen.
- Step 6.** Select the **Select Procedure Location:** field. The Test Set will display a **Choices:** list containing the following items: **Card, ROM, and RAM.**
- Step 7.** Select **ROM.** This allows the loading of various utility programs resident in the Test Set.
- Step 8.** Select the **Select Procedure Filename:** field. The Test Set will display a **Choices:** list containing the following items: **SERVICE4, RFTOOLS, IB_UTIL, LISTOPTS, ST_PLT, and DEMO.**
- Step 9.** Select **IB_UTIL.**
- Step 10.** Press the **k1 (Run Test)** key to run the utility program. The Test Set will display the **IB_UTIL** screen.
- Step 11.** Select the **FILE_XFER** field. The Test Set will display a prompt to insert the SRAM card that contains the test result files.
- Step 12.** Insert the card and select the **Continue** field. The Test Set will display the file transfer menu.
- Step 13.** Select the **Output Port** field and press the knob to select **Serial Port, 9600 baud.** This configures the Test Set to send the data via the SERIAL 9 port at 9600 baud.
- Step 14.** Scroll the cursor down the list of file names to the file that you wish to transfer and press the knob to select it. An asterisk (*) will appear next to the name. You may send more than one file at a time. Scroll to and select any other files that you wish to transfer.

NOTE

All files on the SRAM card are displayed, not just the test result files. If you attempt to transfer files that are not test result data, unexpected results at the printer might occur. Also, transferring code files might result in many pages of code being printed. Look for files with ".txt" appended to the name, which indicates test result files.

- Step 15.** When all files to be transferred have been selected, select the **Start Transfer** field. The data will be sent to the PC via the serial port.
- Step 16.** When data transfer is complete, you may select other files to transfer or exit the utility program by selecting the **Exit Data-Collection-File-Transfer** field.
- Step 17.** To return to the Test Software again, press the **k1 (Run Test)** key from the SOFTWARE MENU screen.

Stop Sending Test Results to a PC or an SRAM Card

Stop sending test results to a PC or SRAM card as follows:

- Step 1.** Press the **Menu** key. The Test Set will display the SOFTWARE MENU screen.
- Step 2.** Press the **k1 (Run Test)** key to start the Test Software. The Test Software will display the Configuration Menu screen.
- Step 3.** Select the **Test Results/Laptop Util/Printer/Serial Setup** field. The Test Software will display the Test Results/Laptop Util/Printer/Serial Setup screen.
- Step 4.** Select the **Send Test Results to** field, then select **Off** from the **Choices:** list.

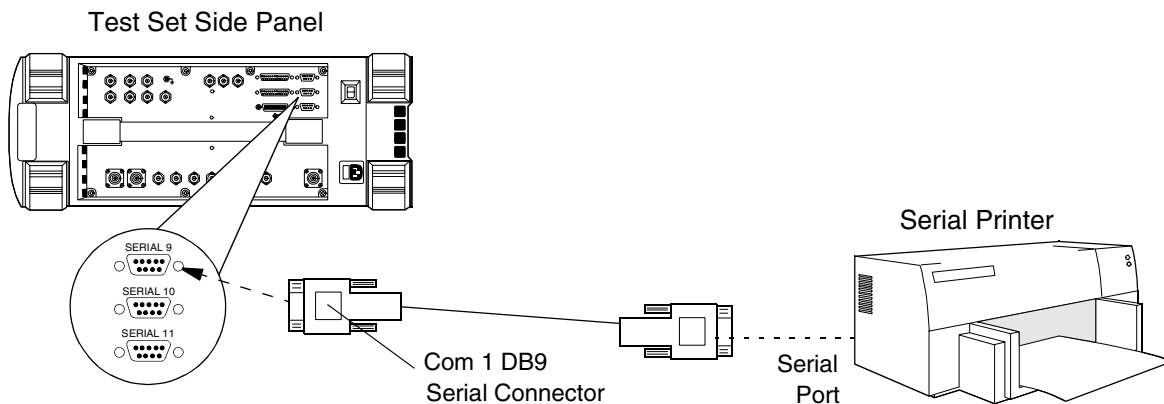
Sending Test Results to a Serial Printer

Test results may be sent directly to a printer through the Test Set SERIAL 9 port. To do so, you must enable sending test results to the printer within the Test Software.

Send test results to a serial printer as follows:

- Step 1.** Press the **Menu** key. The Test Set will display the SOFTWARE MENU screen.
- Step 2.** Press the **k1 (Run Test)** key to start the Test Software. The Test Software will display the Configuration Menu screen.
- Step 3.** Select the **Test Results/Laptop Util/Printer/Serial Setup** field. The Test Software will display the Test Results/Laptop Util/Printer/Serial Setup screen.
- Step 4.** Select the **Send Test Results to Printer at** field, then select **Serial 9** from the **Choices:** list.
- Step 5.** Connect the serial printer to the Test Set SERIAL 9 port (see [Figure 4-19](#)).

Figure 4-19 Test Set to Serial Printer Connection



- Step 6.** Select the **Print Setup** field. The Test Software will display the Print Setup screen.

Step 7. Set the following parameters:

- Lines/Page
- Form Feed (Start and End)
- Printer Model

The Test Set will send test results to the serial printer connected to the SERIAL 9 port until you turn off the **Send Test Results to Printer at** field in the Test Results/Laptop Util/Printer/Serial Setup screen.

Sending Test Results to a Parallel Printer

Test results may be sent to a parallel printer through the Test Set PARALLEL 15 port. To do so, you must enable sending test results to the printer within the Test Software.

Send test results to a parallel printer as follows:

Step 1. Press the **Menu** key. The Test Set will display the SOFTWARE MENU screen.

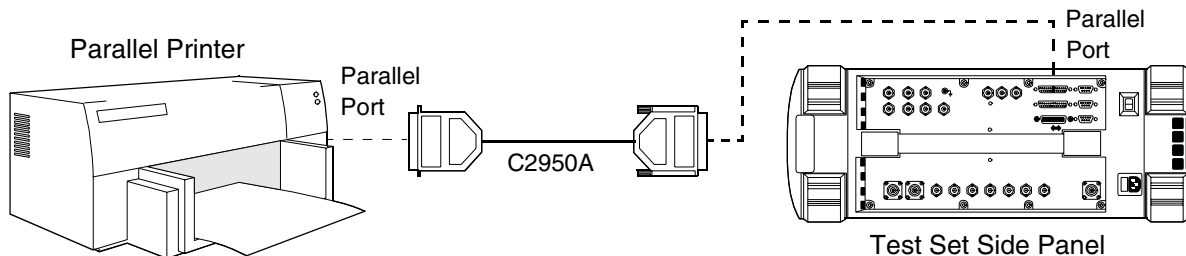
Step 2. Press the **k1 (Run Test)** key to start the Test Software. The Test Software will display the Configuration Menu screen.

Step 3. Select the **Test Results/Laptop Util/Printer/Serial Setup** field. The Test Software will display the Test Results/Laptop Util/Printer/Serial Setup screen.

Step 4. Select the **Send Test Results to Printer at** field, then select **Parallel 15** from the **Choices:** list.

Step 5. Connect the parallel printer to the Test Set PARALLEL 15 port (see [Figure 4-20](#)).

Figure 4-20 Test Set to Parallel Printer Connection



Step 6. Select the **Print Setup** field. The Test Software will display the Print Setup screen.

Step 7. Set the following parameters:

- Lines/Page
- Form Feed (Start and End)
- Printer Model

The Test Set will send test results to the parallel printer connected to the PARALLEL 15 port until you turn off the **Send Test Results to Printer at** field in the Test Results/Laptop Util/Printer/Serial Setup screen.

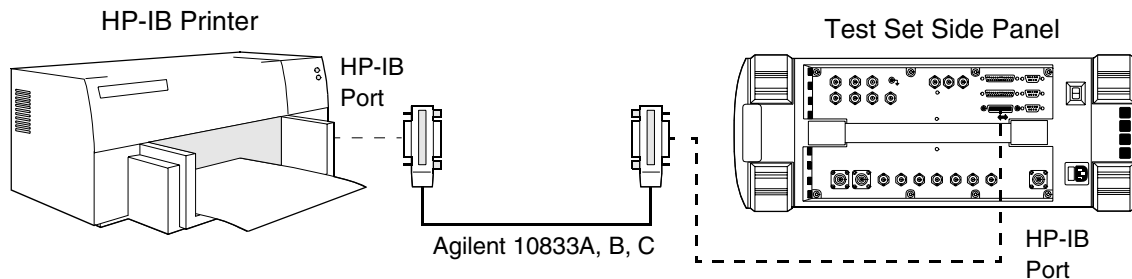
Sending Test Results to an HP-IB Printer

Test results may be sent to an HP-IB printer through the Test Set HP-IB port. To do so, you must enable sending test results to the printer within the Test Software.

Send test results to an HP-IB printer as follows:

- Step 1.** Press the **Menu** key. The Test Set will display the SOFTWARE MENU screen.
- Step 2.** Press the **k1 (Run Test)** key to start the Test Software. The Test Software will display the Configuration Menu screen.
- Step 3.** Select the **Test Results/Laptop Util/Printer/Serial Setup** field. The Test Software will display the Test Results/Laptop Util/Printer/Serial Setup screen.
- Step 4.** Select the **Send Test Results to Printer at** field, then select **HP-IB 701** from the **Choices:** list. Edit the three-digit HP-IB address (the default is 701) in the address field at the right of **HP-IB**.
- Step 5.** Connect the HP-IB printer to the Test Set HP-IB port (see [Figure 4-21](#)).

Figure 4-21 Test Set to an HP-IB Printer Connection



Step 6. Select the **Print Setup** field. The Test Software will display the Print Setup screen.

Step 7. Set the following parameters:

- Lines/Page
- Form Feed (Start and End)
- Printer Model

The Test Set will send test results to the HP-IB printer connected to the HP-IB port until you turn off the **Send Test Results to Printer at** field in the Test Results/Laptop Util/Printer/Serial Setup screen.

Stop Sending Test Results to a Printer

Stop sending test results to a printer as follows:

- Step 1.** Press the **Menu** key. The Test Set will display the SOFTWARE MENU screen.
- Step 2.** Press the **k1 (Run Test)** key to start the Test Software. The Test Software will display the Configuration Menu screen.
- Step 3.** Select the **Test Results/Laptop Util/Printer/Serial Setup** field. The Test Software will display the Test Results/Laptop Util/Printer/Serial Setup screen.
- Step 4.** Select the **Send Test Results to Printer at** field, then select **Off** from the **Choices:** list.

Initializing a RAM Disk

RAM disk is a section of Test Set internal memory that acts much like a flexible disk. Programs in this area of memory may be stored, re-stored, erased, and retrieved.

The RAM disk is partitioned into four separate volumes; 0-3. Each volume is treated as a separate 'disk'. You may also specify the size of each disk in 256-byte increments.

The four RAM disk volumes are designated :MEMORY,0,0 to :MEMORY,0,3. For example, to catalogue the contents of RAM disk volume '0' from the TESTS (IBASIC Controller) screen, enter the following:

```
CAT ":MEMORY,0,0"
```

NOTE

Any existing programs or formatting on RAM is erased if you use the **RAM_MANAGER** program to initialize a RAM disk. Therefore, you should use RAM disks only for short-term storage of files.

Each RAM disk volume must be initialized before it is usable. Volume 0 may be initialized using the **RAM_MANAGER** program from the **IB_UTIL** menu. Volumes 1, 2, and 3 must be initialized from the TESTS (IBASIC Controller) screen.

NOTE

Use only Volume 0 for storing procedures.

The optional 'volume size' in the following procedure allows you specify the memory area to be set aside for each RAM disk in 256-byte blocks.

Initialize volumes 1, 2, or 3 as follows:

Step 1. Press the **Menu** key. The Test Set will display the SOFTWARE MENU screen.

Step 2. Select the **IBASIC IBASIC Cntrl** field from the **SET UP TEST SET:** list.

Step 3. Select the data entry field at the top of the screen.

Step 4. From the list of characters in the **Choices:** list, enter the following command:

```
INITIALIZE ":MEMORY,0,<volume number 1-3>",<volume size>  
or  
INITIALIZE ":MEMORY,0,1",50
```

Select **Done** when finished.

Step 5. Press the **k1 (Run)** key.

Initializing a PC Card

A new PC card or a card from which the battery has been removed and replaced must be initialized before it may be used. This section provides information on the initialization procedure.

Initialize a card as follows:

- Step 1.** Insert the card into the Test Set card slot.
- Step 2.** Press the **Shift** key, then the **Inst Config (I/O Config)** key. The Test Software will display the I/O CONFIGURE screen.
- Step 3.** Select the **Format Card** field. The Test Software will display the message: **Erase and format the PCMCIA Card? (YES/NO)**.
- Step 4.** If you wish to format the card, press the DATA ENTRY **Yes On/Off** key. The Test Set will format the card. Formatting is complete when the cursor stops blinking.

If you do not wish to format the card, press the DATA ENTRY **No ppm W** key.

Operating the Test Set

This section provides information that will help you to operate the Test Set easily and efficiently. It includes a basic overview of the functions of groups of the more commonly used functions. It does not include detailed operation information on those functions. For detailed information on the operation of the display and the various keys and other controls, see the *Agilent Technologies 8935 Series E6380A CDMA Base Station Test Set Reference Guide*, as appropriate.

NOTE

Some Test Set keys include a second title printed in blue above the key. This indicates a *shift* function. Press the blue **Shift** key, then the subject key to activate the title function. For instance, the title **Reset** appears above the **Pause/Continue** key. To reset the Test Software, press the **Shift** key, then the **Pause/Continue (Reset)** key.

Screens

The various operation screens of the Test Software are accessible through several methods, as described in the following paragraphs.

Access the screens to modify test procedures from the **CUSTOMIZE TEST PROCEDURE:** list in the lower section of the **SOFTWARE MENU** screen. These screens are:

- **TESTS (Channel Information)** – Access this screen to verify or change the information in the frequency table. (The frequency table is not used in this application. Therefore, this screen is not used in this application.)
- **TESTS (Test Parameters)** – Access this screen to verify or change the values of parameters used in the **TESTS**.
- **TESTS (Order of Tests)** – Access this screen to verify or change the **TESTS** complement or order in which **TESTS** will be performed. (Tests are performed individually in this application. Therefore, this screen is not used in this application.)
- **TESTS (Pass/Fail Limits)** – Access this screen to verify or change the values of pass/fail limits used in the **TESTS**.
- **TESTS (Save/Delete Procedure)** – Access this screen to save procedures to the Test Set internal RAM or an SRAM card, or delete procedures from those same locations.

NOTE

Three additional screens are ordinarily used to configure and set up the Test Set for operation from the **SET UP TEST SET:** list in the lower section of the **SOFTWARE MENU** screen. These screens are:

TESTS (Execution Conditions)
TESTS (External Devices)
and
TESTS (Printer Setup)

These screens are not used in the Test Software. All relevant functions in these screens are set by other means, such as parameters, in the Test Software.

Access the Configuration Menu screen, from which all operations inside the Test Software are invoked, from the SOFTWARE MENU screen by selecting the **Run Test** field or pressing the **k1 (Run Test)** key. For detailed information on this screen, see “Using the Configuration Menu Screen” on page 21.

NOTE

If you select the screen title bar at the top of the SOFTWARE MENU screen, the Test Software will display a menu listing the ancillary operation screens. These screens are not used by the Test Software.

SOFTWARE Keys

The SOFTWARE keys (see Figure 4-22), **Menu** and **Pause/Continue (Reset)**, control the basic start/pause/stop functions of the Test Set and Test Software.

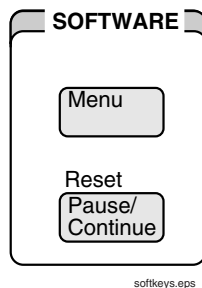
Press the **Menu** key to display the SOFTWARE MENU screen, which is the screen from which all Test Set operations start.

Press the **Pause/Continue** key to pause the Test Set or Test Software operation, then press it again to re-start the operation at the same place.

Press the **Shift** key, then the **Pause/Continue (Reset)** key to reset the Test Set or Test Software.

NOTE

The Test Software cannot be “continued” after the **Shift** and **Pause/Continue (Reset)** keys have been pressed. Press these keys only if the Test Software must be stopped and pressing the **Pause/Continue** key does not do so.

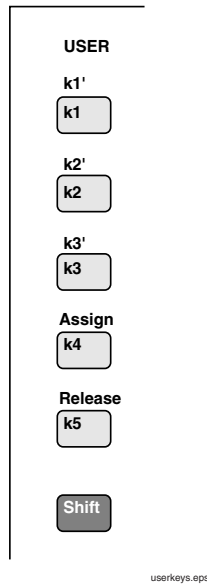
Figure 4-22**SOFTWARE Keys****USER Keys**

The five USER keys, **k1** through **k5** (see Figure 4-23), are programmable and control various functions according to current activities in the Test Software. The keys are listed along with the programmed functions in the right-hand section of appropriate screens. Only appropriate keys are shown in each screen instance. You may use these keys for more efficient operation instead of scrolling the cursor to an item and pressing the knob.

NOTE

Each USER key includes a second title printed in blue above the key. This *shifted* function is part of the key programmability. However, currently, no USER key *shifted* functions are used in the Test Software.

Figure 4-23 USER Keys

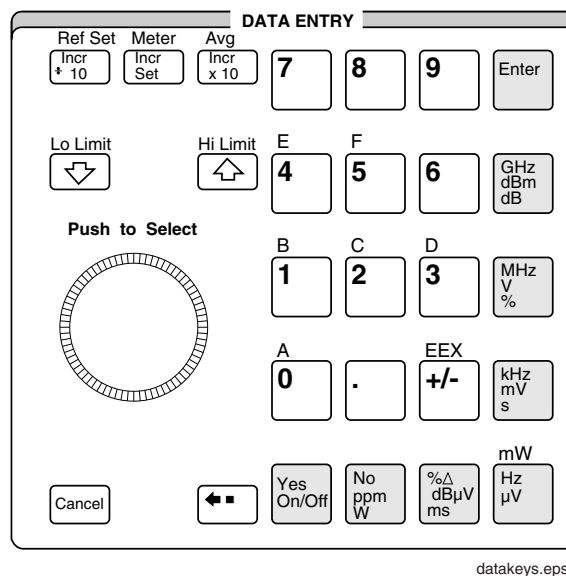


DATA ENTRY Keys

The DATA ENTRY keys include the 0 through 9 number keys plus the associated keys required for entering number values and the various characteristics of those values (see Figure 4-24). (Note that a number of the DATA ENTRY keys are *shifted* keys.)

Although it is obviously not a key, the cursor control/entry knob is also located in the DATA ENTRY section of the Test Set front panel for convenience. Rotate the knob to scroll the cursor, then press the knob to select the item indicated by the cursor.

Figure 4-24 DATA ENTRY Keys



GENERATOR/ANALYZER Keys

The GENERATOR/ANALYZER keys invoke the various testing tools, and are not used by the Test Software.

NOTE Make certain that you do not inadvertently press one of these keys while the Test Software is running. Unpredictable test results could occur.

STATE Keys

The STATE keys allow user control over certain Test Set operational states, and are not used by the Test Software.

NOTE Make certain that you do not inadvertently press one of these keys while the Test Software is running. Unpredictable test results could occur.

UTILS Keys

The UTILS keys provide the means to reach certain functions that control utilitarian aspects of Test Set operation, and are not used by the Test Software.

NOTE Make certain that you do not inadvertently press one of these keys while the Test Software is running. Unpredictable test results could occur.

Securing/Un-Securing Procedures

This section describes the processes for securing and un-securing a procedure.

NOTE If a procedure is located in the Test Set RAM, securing that procedure will result in initializing a section of the RAM. See [“Initializing a RAM Disk” on page 77](#).

NOTE Loading and running the utility to perform these procedures will replace any programs and procedures in the Test Set internal RAM. Thus, the Test Software must be reloaded when this procedure is complete. This requires that you have the Test Software PC card with you on-site.

Securing a Procedure

After you have set up the Test Software with a testing order, channel information, test parameters, and pass/fail limits, thereby creating a procedure, you might wish to secure it. This will prevent the viewing and changing of those functions. In this process, you may select the items that you wish to secure. Use the IBASIC SECURE_IT program in the Test Set ROM to do this.

You might wish to secure the procedure that is supplied with the Test Software. It is shipped unsecured.

Secure a Procedure as follows:

Step 1. Press the **Menu** key. The Test Set will display the SOFTWARE MENU screen.

Step 2. Select the **Select Procedure Location:** field. The Test Set will display a **Choices:** list.

Step 3. Select **ROM**.

Step 4. Select the **Select Procedure Filename:** field. The Test Set will display a **Choices:** list.

Step 5. Select **IB_UTIL**.

Step 6. Press the **k1 (Run Test)** key. The Test Set will display the IB_UTIL menu.

Step 7. Select the **SECURE_IT** field. The Test Set will display a menu containing two possible locations (**Card** or **RAM**).

Step 8. Select the location of the procedure that you wish to secure.

NOTE RAM refers to the section of the Test Set memory that is assigned as a RAM disk. Before selecting RAM, you must initialize the RAM as a disk. See [“Initializing a RAM Disk” on page 77](#).

Step 9. Proceed with the on-screen instructions. You might wish to secure only one of the items, such as pass/fail limits.

Step 10. When prompted to enter the **pass number** (password), enter any sequence of 9 or less numerals using the DATA ENTRY keys. The numerals may be 0 through 9 in any order.

Un-Securing a Procedure

After you have secured a procedure, you may un-secure it. In this process, you may select the items that you wish to un-secure. Use the IBASIC SECURE_IT program in the Test Set ROM to do this. To un-secure a procedure, you must know the **pass number**.

Un-secure a procedure as follows:

- Step 1.** Press the **Menu** key. The Test Set will display the SOFTWARE MENU screen.
- Step 2.** Select the **Select Procedure Location:** field. The Test Set will display a **Choices:** list.
- Step 3.** Select **ROM**.
- Step 4.** Select the **Select Procedure Filename:** field. The Test Set will display a **Choices:** list.
- Step 5.** Select **IB_UTIL**.
- Step 6.** Press the **k1 (Run Test)** key. The Test Set will display the IB_UTIL menu screen.
- Step 7.** Select the **SECURE_IT** field. The Test Set will display a menu containing two possible locations (**Card** or **RAM**).
- Step 8.** Select the location of the procedure that you wish to un-secure.
- Step 9.** Enter the name of the procedure that you wish to un-secure.

NOTE

If the procedure includes any item that is secured, you will be prompted for the **pass number**.

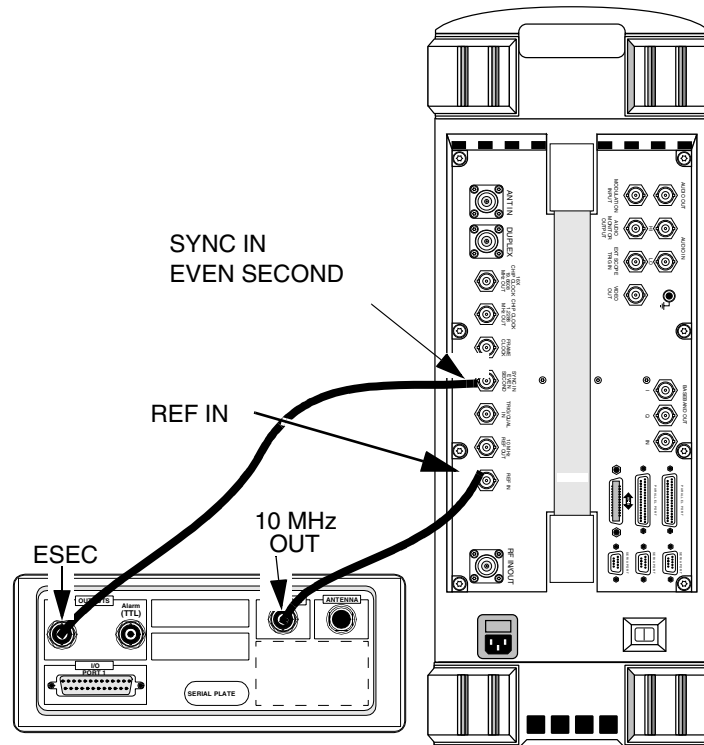
- Step 10.** Proceed with the on-line instructions. Select the items that you wish to un-secure.
- Step 11.** When prompted, enter the **pass number** using the DATA ENTRY keys.

Test Set to GPS Time and Frequency Reference Receiver Connections

Figure 4-25 shows the connections to the Test Set when using a Symmetricom 58503A GPS Time and Frequency Reference Receiver with the optional 1PP2S output to establish a time base. This configuration uses a GPS signal for the Test Set timebase instead of connecting to the Base Station.

Figure 4-25

Symmetricom 58503A GPS Time and Frequency Reference Receiver Connections



Utilities

The Test Software contains utilities that are useful to both general testing and advanced testing operations. These utilities are described in this section.

RF Tools

For information on using the RF Tools Utilities, see the *Agilent Technologies 8935 Series E6380A CDMA Base Station Test Set Reference Guide*.

5 Test, Parameter, and Pass/Fail Limit Descriptions

This chapter provides descriptions of each of the procedures, tests, test suites, parameters, and pass/fail limits contained in the Test Software.

Procedures Supplied

The Test Software is supplied on a PC card. Also on the same card are ten pre-programmed procedures. Each procedure selects a suite of TESTs, and includes the parameters and specifications (pass/fail limits) used in those TESTs. All of the parameters and pass/fail limits are set to default values.

You may customize a procedure and save it by another name for a particular application, or you may construct a procedure, perhaps using one of those procedures as a model.

The following sections describe the procedures.

PROCEDURE 1 — MET_1900

This procedure is used for installation of the Nortel Metro Cell SFRM 1900-MHz Base Station.

The procedure selects [Test Suite 8 — Nortel Metro Cell 1900 MHz Install](#) as the default on the Configuration Menu screen. The default is set by setting [PARAMETER 5 — GN Test Type \[Enter number on Conf Menu\]](#) to 8.

This Test Suite contains one TEST group for commissioning Base Stations, and includes the standard TESTs required for Base Station installation. In this Test Suite, the Spectral Interference Evaluation test is done without an external low-noise amplifier (LNA). This is selected by setting [PARAMETER 3 — GN Spectral Check with LNA \[0=no 1=yes\]](#) to 0.

PROCEDURE 2 — MET_800

This procedure is used for installation of the Nortel Metro Cell SFRM 800-MHz Base Station.

The procedure selects [Test Suite 9 — Nortel Metro Cell 800 MHz Install](#) as the default on the Configuration Menu screen. The default is set by setting [PARAMETER 5 — GN Test Type \[Enter number on Conf Menu\]](#) to 9.

This Test Suite contains one TEST group for commissioning Base Stations, and includes the standard TESTs required for Base Station installation. In this Test Suite, the Spectral Interference Evaluation test is done without an external low-noise amplifier (LNA). This is selected by setting [PARAMETER 3 — GN Spectral Check with LNA \[0=no 1=yes\]](#) to 0.

PROCEDURE 3 — MFRM1900

This procedure is used for installation of the Nortel Metro Cell MFRM 1900-MHz Base Station.

The procedure selects [Test Suite 11 — Nortel Metro Cell MFRM 1900 MHz Install](#) as the default on the Configuration Menu screen. The default is set by setting [PARAMETER 5 — GN Test Type \[Enter number on Conf Menu\]](#) to 8.

This Test Suite contains one TEST group for commissioning Base Stations, and includes 16 standard TESTs required for Base Station installation. In this Test Suite, the Spectral Interference Evaluation test is done without an external low-noise amplifier (LNA). This is selected by setting [PARAMETER 3 — GN Spectral Check with LNA \[0=no 1=yes\]](#) to 0.

PROCEDURE 4 — MFRM800

This procedure is used for installation of the Nortel Metro Cell MFRM 800-MHz Base Station.

The procedure selects [Test Suite 12 — Nortel Metro Cell MFRM 800 MHz Install](#) as the default on the Configuration Menu screen. The default is set by setting [PARAMETER 5 — GN Test Type \[Enter number on Conf Menu\]](#) to 9.

This Test Suite contains one TEST group for commissioning Base Stations, and includes 16 standard TESTs required for Base Station installation. In this Test Suite, the Spectral Interference Evaluation test is done without an external low-noise amplifier (LNA). This is selected by setting [PARAMETER 3 — GN Spectral Check with LNA \[0=no 1=yes\]](#) to 0.

PROCEDURE 5 — RURAL

This procedure is used for installation of the Nortel Rural Cell Base Station.

The procedure selects [Test Suite 10 — Nortel Rural Cell Install](#) as the default on the Configuration Menu screen. The default is set by setting [PARAMETER 5 — GN Test Type \[Enter number on Conf Menu\]](#) to 10.

This Test Suite contains one TEST group for commissioning Base Stations, and includes the standard TESTs required for Base Station installation. In this Test Suite, the Spectral Interference Evaluation test is done without an external low-noise amplifier (LNA). This is selected by setting [PARAMETER 3 — GN Spectral Check with LNA \[0=no 1=yes\]](#) to 0.

PROCEDURE 6 — _1900

This procedure is used for installation and troubleshooting of the Nortel Legacy 1900-MHz Base Station.

The procedure selects [Test Suite 1 — CDMA 1900 MHz Install](#) as the default on the Configuration Menu screen. The default is set by setting [PARAMETER 5 — GN Test Type \[Enter number on Conf Menu\]](#) to 1.

This Test Suite contains one TEST group for commissioning Base Stations, and includes the standard TESTs required for Base Station installation. It also includes additional TESTs that may be used for installation. In this Test Suite, the Spectral Interference Evaluation test is done with an external low-noise amplifier (LNA). This is selected by setting [PARAMETER 3 — GN Spectral Check with LNA \[0=no 1=yes\]](#) to 1.

PROCEDURE 7 — _C800

This procedure is used for installation and troubleshooting of the Nortel Legacy C800-MHz Base Station.

The procedure selects [Test Suite 3 — CDMA C800 Install](#) as the default on the Configuration Menu screen. The default is set by setting [PARAMETER 5 — GN Test Type \[Enter number on Conf Menu\]](#) to 3.

This Test Suite contains one TEST group for commissioning Base Stations, and includes the standard TESTs required for Base Station installation. It also includes additional TESTs that may be used for installation. In this Test Suite, the Spectral Interference Evaluation test is done with an external low-noise amplifier (LNA). This is selected by setting [PARAMETER 3 — GN Spectral Check with LNA \[0=no 1=yes\]](#) to 1.

PROCEDURE 8 — _FCP800

This procedure is used for installation and troubleshooting of the Nortel Legacy FCP 800-MHz Base Station.

The procedure selects [Test Suite 7 — CDMA FCP800 Install](#) as the default on the Configuration Menu screen. The default is set by setting [PARAMETER 5 — GN Test Type \[Enter number on Conf Menu\]](#) to 7.

This Test Suite contains one TEST group for commissioning Base Stations, and includes the standard TESTs required for Base Station installation. It also includes additional TESTs that may be used for installation. In this Test Suite, the Spectral Interference Evaluation test is done with an external low-noise amplifier (LNA). This is selected by setting [PARAMETER 3 — GN Spectral Check with LNA \[0=no 1=yes\]](#) to 1.

PROCEDURE 9 — _MACRO

This procedure is used for installation of the Nortel Legacy Macro Base Station.

The procedure selects [Test Suite 5 — CDMA Macro Install](#) as the default on the Configuration Menu screen. The default is set by setting [PARAMETER 5 — GN Test Type \[Enter number on Conf Menu\]](#) to 5.

This Test Suite contains one TEST group for commissioning Base Stations, and includes the standard TESTs required for Base Station installation. It also includes additional TESTs that may be used for installation. In this Test Suite, the Spectral Interference Evaluation test is done with an external low-noise amplifier (LNA). This is selected by setting [PARAMETER 3 — GN Spectral Check with LNA \[0=no 1=yes\]](#) to 1.

Test Descriptions

Each TEST consists of one measurement or more. One TEST or more may constitute a Test Suite. In most instances, you may change the values of the parameters and specifications (pass/fail limits) that are used in a TEST, but you may not change the measurements that the TEST will perform.

Generally, the order in which you perform the TESTs is not important. However, for the greatest efficiency, you should perform the TESTs in the order shown on the Test Menu screen. For instance, the transmit TESTs are listed together on the screen. This provides for blossoming the Base Station at the start of the transmit test sequence, then not wilting the Base Station until after all of the transmit TESTs have been performed. This prevents wasting time in needlessly blossoming and wilting the Base Station.

The TESTs are derived from the Nortel Cellular Handbook and include the following, in alphabetical order:

- Adjacent Channel Power Test
- Check Pilot, Paging, Sync, and OCNS
- Code Domain Channel Test
- Code Domain Measurements
- Determine Cable Loss Insertion Factors
- Emission Bandwidth Test
- Go to Code Domain Analyzer
- Go to Spectrum Analyzer
- Measure Device Loss
- Measure Test Cable (and Attenuator) Loss
- MFRM Total Output Power Test
- OCNS Channels Code Domain Measurements
- Pilot Only Check
- Receive Path Verification
- RX0 Receive FER Test
- RX1 Receive FER Test
- RX0 Receive Path Gain
- RX1 Receive Path Gain
- RX0 Receive Power Test
- RX1 Receive Power Test
- RF (or HIP-D, or MCPA RMS) Power Sensor Verification
- Spectral Interference Evaluation
- Spectral Regrowth Test

Test Descriptions

- Spurious Emission Test
- Test Set Calibration and PAM Warm-Up

These TESTs are described on succeeding pages.

NOTE

It is important to remember that, of the specifications listed in each TEST description, not all are necessarily used for each Base Station type.

Blossoming the Base Station

When you are prompted to blossom the Base Station, dependent upon the Base Station type, configure the Base Station code channels and gain as listed in the following paragraphs. For information on configuring the channels and gains for particular Base Stations, refer to the appropriate Nortel CDMA Testing Installation Method.

For Legacy Base Stations:

- Pilot Channel – 254

For Metro Cell IS-95 Base Stations:

- Pilot Channel – 254
- Sync Channel – 123
- Paging Channel – 245
- 6 OCNS Channels – 174

For Metro Cell IS-2000 1xRTT Base Stations:

- Pilot Channel – 254
- Sync Channel – 123
- Paging Channel – 245
- 5 OCNS Radio Configuration 3 (RC3) Fundamental Channels – 174
- 1 OCNS Radio Configuration 3 (RC3) 16x Supplemental Channels – 174

Testing MFRM Metro Cell Base Stations

It is also important to remember that the MFRM Metro Cell Base Station can transmit as many as three carriers. In order to test this Base Station properly, all three carriers must be checked. Following is the recommended test sequence for MFRM Metro Cell Base Stations. The MFRM Test Menu is arranged so as to repeat the sequence on the menu three times, one for each carrier.

Test the three carriers on the Base Station on adjacent CDMA channels. For instance, in the cellular band, the channels might be 384, 425, and 466. In the PCS band, the channels might be 500, 525, and 550. You must use three adjacent channels appropriate to the frequency band. Start the sequence of TESTs on the lowest carrier channel selected.

Set up the Base Station and the Test Software to perform TESTs on the lower carrier channel. Perform the following TESTs:

- Test Set Calibration and PAM Warm-Up – (Make connections and blossom one carrier of the Base Station during this TEST.)
- Check Pilot, Paging, Sync, and OCNS
- MCPA RMS Power Sensor Verification
- Code Domain Channel Test
- OCNS Channels Code Domain Measurement – (Blossom all three carriers during this TEST. Wilt the other two carriers after this TEST. Leave the channel under test blossomed.)
- Spectral Regrowth Test
- Adjacent Channel Power Test
- RX0 Receive Power Test
- RX0 Receive FER Test
(Wilt the Base Station.)
- RX1 Receive Power Test – (Change connections and blossom the Base Station.)
- RX1 Receive FER Test
(Wilt the Base Station.)

Change the Base Station and the Test Software to perform TESTs on the middle carrier channel. Perform the following TESTs:

- Test Set Calibration and PAM Warm-Up – (Change connections and blossom one carrier of the Base Station during this TEST.)
- Check Pilot, Paging, Sync, and OCNS
- MCPA RMS Power Sensor Verification
- Code Domain Channel Test
- OCNS Channels Code Domain Measurement – (Blossom all three carriers during this TEST. Wilt the other two carriers after this TEST. Leave the channel under test blossomed.)
- Spectral Regrowth Test
- Adjacent Channel Power Test
- RX0 Receive Power Test
- RX0 Receive FER Test
(Wilt the Base Station.)
- RX1 Receive Power Test – (Change connections and blossom the Base Station.)
- RX1 Receive FER Test
(Wilt the Base Station.)

Test Descriptions

Select the Multiple Carrier Test Menu.

- MFRM Total Output Power Test – (Change connections and blossom all three carriers on the Base Station.)
- Spectral Regrowth Test
(Wilt all three carriers.)

Change the Base Station and the Test Software to perform TESTs on the upper carrier channel. Perform the following TESTs:

- Test Set Calibration and PAM Warm-Up – (Blossom one carrier of the Base Station during this TEST.)
- Check Pilot, Paging, Sync, and OCNS
- MCPA RMS Power Sensor Verification
- Code Domain Channel Test
- OCNS Channels Code Domain Measurement – (Blossom all three carriers during this TEST. Wilt the other two carriers after this TEST. Leave the channel under test blossomed.)
- Spectral Regrowth Test
- Adjacent Channel Power Test
- RX0 Receive Power Test
- RX0 Receive FER Test
(Wilt the Base Station.)
- RX1 Receive Power Test – (Change connections and blossom the Base Station.)
- RX1 Receive FER Test
(Wilt the Base Station.)

Adjacent Channel Power Test

NOTE

This TEST is applicable to Metro Cell and Rural Cell Base Stations only.

This TEST may be invoked from either the Test Menu screen or the Utilities Menu screen.

This TEST verifies power in a 30-kHz adjacent channel relative to the 1.23-MHz channel of the carrier. The offset is 885 kHz for 1900-MHz Base Stations and 750 kHz for 800-MHz Base Stations. The Test Software examines the 30-kHz channels at 885 (or 750) kHz above and below the center frequency.

In more detail, it verifies that the 1.23-MHz transmit signal is adequately filtered (reduced) at the adjacent channel frequencies.

No Parameters are used in this TEST.

The Pass/Fail Limits used in this TEST are:

- [PASS/FAIL LIMIT 19 — TX Adjacent Channel Pow at 750 kHz Offsets](#)
- [PASS/FAIL LIMIT 20 — TX Adjacent Channel Pow at 885 kHz Offsets](#)

After selecting the Test Suite, invoke and perform this TEST from the Configuration Menu screen or the Utilities Menu screen as follows:

CAUTION

Before disconnecting any Base Station cables, verify that the site is wilted and is not producing RF power.

Step 1. Either:

Press the **k1 (Test Menu)** key if you wish to invoke the TEST from the Configuration Menu screen. The Test Software will display the Test Menu screen.

or

Press the **k3 (Utilities)** key if you wish to invoke the TEST from the Utilities Menu screen. The Test Software will display the Utilities Menu screen.

Step 2. If you pressed the **k1 (Test Menu)** key:

1. Select the **Adjacent Channel Power Test** field from the Configuration Menu screen.
2. Follow the on-screen directions. (See [“Blossoming the Base Station” on page 92](#) for detailed information on channels and gains.)

If you pressed the **k3 (Utilities)** key:

1. Select the **Adjacent Channel Power Test** field from the Utilities Menu screen.
2. Follow the on-screen directions. (See [“Blossoming the Base Station” on page 92](#) for detailed information on channels and gains.)

Check Pilot, Paging, Sync, and OCNS

NOTE

This TEST is applicable to Metro Cell and Rural Cell Base Stations only.

This TEST invokes the code domain analyzer built into the Test Set so that you may verify that the Pilot, Paging, and Sync channels (Walsh codes 0, 1, and 32, respectively) and OCNS channels are being transmitted by the Base Station.

NOTE

The Code Domain Analyzer Test Function of the Test Set operates outside of the Test Software. Invoking the analyzer pauses the Test Software in its current state.

No Parameters are used in this TEST.

No Pass/Fail Limits are used in this TEST.

After selecting the Test Suite, invoke and perform this TEST from the Configuration Menu screen as follows:

CAUTION

Before disconnecting any Base Station cables, verify that the site is wilted and is not producing RF power.

- Step 1.** Press the **k1 (Test Menu)** key. The Test Software will display the Test Menu screen.
- Step 2.** Select the **Check Pilot, Paging, Sync, and OCNS** field.
- Step 3.** Follow the on-screen directions. (See [“Blossoming the Base Station”](#) on page 92 for detailed information on channels and gains.)

Code Domain Channel Test

NOTE

This TEST is applicable to Metro Cell and Rural Cell Base Stations only.

If **IS-95** is selected in the CDMA Standard field in the Configuration Menu screen, the following actions take place:

- The TEST checks the channel power level of the CDMA carrier under test in dBm.
- The TEST checks the relative power level in dB as compared with the channel power of all active Walsh code channels, including pilot, paging, and sync.
- The TEST reports the noise level in dB as compared with the channel power of the highest unused Walsh code.

If **IS-2000 1xRTT** is selected in the CDMA Standard field in the Configuration Menu screen, the following actions take place:

- The TEST checks the channel power level of the CDMA carrier under test in dBm.
- The TEST checks the relative power level in dB as compared with the channel power of the pilot, paging, and sync channels.
- The TEST checks the relative power level and data rate of the fundamental traffic channels.
- The TEST checks the relative power level and data rate of the supplemental channels.
- The TEST reports the noise level in dB as compared with the channel power of the highest unused Walsh code.

No Parameters are used in this TEST.

One Pass/Fail Limit is used in this TEST. It is:

- [PASS/FAIL LIMIT 31 — TX Inactive Code Channel Maximum Level](#)

After selecting the Test Suite, invoke and perform this TEST from the Configuration Menu screen as follows:

CAUTION

Before disconnecting any Base Station cables, verify that the site is wilted and is not producing RF power.

- Step 1.** Press the **k1 (Test Menu)** key. The Test Software will display the Test Menu screen.
- Step 2.** Select the **Code Domain Channel Test** field from the Test Menu screen.
- Step 3.** Follow the on-screen directions. (See [“Blossoming the Base Station” on page 92](#) for detailed information on channels and gains.)

Code Domain Measurements

NOTE

This TEST is applicable to Legacy Base Stations only.

This TEST verifies that the rho, frequency error, time offset, and carrier feedthrough values of the transmitted RF signal from the Base Station are within the prescribed limits.

No Parameters are used in this TEST.

The Pass/Fail Limits used in this TEST are:

- [PASS/FAIL LIMIT 21 — TX Code Domain Carrier Feedthru](#)
- [PASS/FAIL LIMIT 22 — TX Code Domain Carrier Feedthru Metro](#)
- [PASS/FAIL LIMIT 23 — TX Code Domain Frequency Error](#)
- [PASS/FAIL LIMIT 24 — TX Code Domain Frequency Error Metro](#)
- [PASS/FAIL LIMIT 25 — RX Code Domain Rho](#)
- [PASS/FAIL LIMIT 26 — RX Code Domain Rho Metro Cell](#)
- [PASS/FAIL LIMIT 27 — TX Code Domain Time Offset](#)
- [PASS/FAIL LIMIT 28 — TX Code Domain Time Offset Metro Cell](#)
- [PASS/FAIL LIMIT 29 — TX Code Domain Time Offset w/IMF or Comb](#)
- [PASS/FAIL LIMIT 31 — TX Inactive Code Channel Maximum Level](#)

After selecting the Test Suite, invoke and perform this TEST from the Configuration Menu screen as follows:

CAUTION

Before disconnecting any Base Station cables, verify that the site is wilted and is not producing RF power.

- Step 1.** Press the **k1 (Test Menu)** key. The Test Software will display the Test Menu screen.
- Step 2.** Select the **Code Domain Measurements** field from the Test Menu screen.
- Step 3.** Follow the on-screen directions. (See [“Blossoming the Base Station”](#) on page 92 for detailed information on channels and gains.)

Determine Cable Loss Insertion Factors

NOTE

This TEST determines the losses through the Base Station cables only, and is applicable to Legacy 1900-MHz Base Stations only.

The cables connecting the 1900-MHz RFFE to the Base Station must be measured for insertion loss before the start of testing. These cables include the TX, RX0, RX1, and Test cables for each sector. The insertion loss of each cable must be entered into the configuration program of the Base Station Maintenance Unit (BMU) or Vortex and configuration scripts must be downloaded into the Base Station.

There are three methods for performing this TEST. These are as follows:

Method 1 (typical)

Method 1 measures the loss of each RFFE cable independently by connecting two test cables, TC1 and TC2, to the cable under test (one on each end). If the test cables in the Nortel E8302A Cable Kit will span the distance from the Test Set to both ends of the cables under test, use this Method.

Method 2 (for Remote RFFE)

Method 2 calculates the loss of each RFFE cable by jumpering the TX and RX cables together (one set at a time) at the remote RFFE, measuring the combination of the RX and TX cables, and calculating the loss of each cable. In this method, the test cables (TC1 and TC2) will be connected to the RX and the TX cables at the Base Station. (The RFFE end of the TX and RX cables must be connected together using a jumper cable.) Use this procedure when the RFFE is located some distance from the Base Station and the test cables will not reach from the Test Set to the RFFE and back to the Test Set.

Method 3 (for Remote RFFE)

Method 3 uses an external power meter to measure the loss of the cables. The Test Set will provide a signal from its DUPLEX OUT port for the power meter. Use this procedure when the RFFE is located some distance from the Base Station and the test cables will not reach from the Test Set to the RFFE and back to the Test Set. This procedure uses a separate Agilent Technologies 437 Power Meter at the RFFE to measure the cable insertion loss factors.

No Parameters are used in this TEST.

No Pass/Fail Limits are used in this TEST.

Test Descriptions

After selecting the Test Suite, invoke and perform this TEST from the Configuration Menu screen as follows:

CAUTION

Before disconnecting any Base Station cables, verify that the site is wilted and is not producing RF power.

- Step 1.** Press the **k1 (Test Menu)** key. The Test Software will display the Test Menu screen.
- Step 2.** Select the **Determine Cable Insertion Loss Factors** field from the Test Menu screen. The Test Software will display a screen that provides for selection among the three methods of testing the cables between the RFFE and the Base Station.
- Step 3.** Select the method for performing the TEST by pressing the **k1 (Method 1)** key, the **k2 (Method 2)** key, or the **k3 (Method 3)** key, as appropriate, from that screen.
- Step 4.** Follow the on-screen directions.

Emission Bandwidth Test

This TEST measures the emissions outside of two points centered around the carrier. (Emission bandwidth is defined as two points centered around the carrier, outside of which all emissions are attenuated at least 26 dB below the transmitter power.) The Test Software measures the emissions relative to the two points. The pass/fail limits set the two points about which to test.

No Parameters are used in this TEST.

One Pass/Fail Limit is used in this TEST. It is:

- [PASS/FAIL LIMIT 30 — TX Emission Bandwidth](#)

Invoke and perform this TEST from the Configuration Menu screen as follows:

CAUTION

Before disconnecting any Base Station cables, verify that the site is wilted and is not producing RF power.

- Step 1.** From the Configuration Menu screen, select the **More** field. The Test Software will display the More menu.
- Step 2.** Select the **Utilities** field. The Test Software will display the Utilities Menu screen.
- Step 3.** Select the **Emission Bandwidth Test** field.
- Step 4.** After following the on-screen directions to operate the Test Function, press the **Pause/Continue** key to return to the Test Software at the Test Menu screen. (See [“Blossoming the Base Station” on page 92](#) for detailed information on channels and gains.)

Test Descriptions

Go to Code Domain Analyzer

NOTE

The Code Domain Analyzer Test Function of the Test Set operates outside of the Test Software. Invoking the analyzer pauses the Test Software in its current state.

This Test Function allows you to use the Code Domain Analyzer built into the Test Set. While the Code Domain Analyzer is operating, the state of the Test Software is saved. This allows you to use the analyzer, then return to Test Software control.

No Parameters are used in this Test Function.

No Pass/Fail Limits are used in this Test Function.

After selecting the Test Suite, invoke and perform this Test Function from the Configuration Menu screen as follows:

CAUTION

Before disconnecting any Base Station cables, verify that the site is wilted and is not producing RF power.

- Step 1.** Press the **k1 (Test Menu)** key. The Test Software will display the Test Menu screen.
- Step 2.** Select the **Go to Code Domain Analyzer** field from the Test Menu screen.
- Step 3.** After following the on-screen directions to operate the Test Function, press the **Pause/Continue** key to return to the Test Software at the Test Menu screen. (See [“Blossoming the Base Station”](#) on page 92 for detailed information on channels and gains.)

Go to Spectrum Analyzer

NOTE

The Spectrum Analyzer Test Function of the Test Set operates outside of the Test Software. Invoking the analyzer pauses the Test Software in its current state.

This function allows you to use the Spectrum Analyzer built into the Test Set. While the Spectrum Analyzer is operating, the state of the Test Software is saved. This allows you to use the analyzer, then return to Test Software control.

No Parameters are used in this Test Function.

No Pass/Fail Limits are used in this Test Function.

After selecting the Test Suite, invoke this Test Function from the Configuration Menu screen as follows:

CAUTION

Before disconnecting any Base Station cables, verify that the site is wilted and is not producing RF power.

- Step 1.** Press the **k1 (Test Menu)** key. The Test Software will display the Test Menu screen.
- Step 2.** Select the **Go to Spectrum Analyzer** field from the Test Menu screen.
- Step 3.** After following the on-screen directions to operate the Test Function, press the **Pause/Continue** key to return to the Test Software at the Test Menu screen. (See [“Blossoming the Base Station”](#) on page 92 for detailed information on channels and gains.)

Measure Device Loss

NOTE

This TEST is applicable to Metro Cell 800-MHz and Rural Cell Base Stations only.

This TEST measures the insertion loss of the TX IMF filter and the RX splitter. Because the IMF filter and the splitter are passive devices that do not report either presence or losses, the Base Station neither recognizes nor compensate for the losses through these devices. Thus, the losses must be measured and supplied to the Base Station for compensation to take place.

NOTE

As many as four losses may be saved by pressing the appropriate USER key. Press the **k2**, **k3**, **k4**, or **k5**, (**Save Dx**) key (where x = 1, 2, 3, or 4).

No Parameters are used in this TEST.

No Pass/Fail Limits are used in this TEST.

After selecting the Test Suite, invoke and operate this TEST from the Configuration Menu screen as follows:

- Step 1.** Press the **k1 (Test Menu)** key. The Test Software will display the Test Menu screen.
- Step 2.** Select the **Measure Device Loss** field from the Test Menu screen.
- Step 3.** Follow the on-screen directions.

Measure Test Cable (and Attenuator) Loss

NOTE

This TEST may be invoked from either the Test Menu screen or the Utilities Menu screen.

This TEST verifies that no cable damage or attenuator has occurred since the last testing procedure. (Test cable loss and attenuator loss factors must be determined each time testing is started.) These values allow the Test Software to provide accurate, repeatable measurements for installing and maintaining a Base Station. Measuring cable loss also allows you to determine when it is necessary to replace worn or faulty cables that could be damaged internally but show no signs of wear or damage. Measuring attenuator loss allows you to determine when it is necessary to replace an attenuator for the same reasons.

NOTE

All losses must be saved by pressing the **k3 (Save Data)** key after each measurement is completed so as to enter the loss automatically on the Configuration Menu screen.

No Parameters are used in this TEST.

No Pass/Fail Limits are used in this TEST.

After selecting the Test Suite, invoke and operate this TEST from the Configuration Menu screen or the Utilities Menu screen as follows:

Step 1. Either:

Press the **k1 (Test Menu)** key if you wish to invoke the TEST from the Test Menu screen. The Test Software will display the Test Menu screen.

or

Press the **k3 (More)** key if you wish to invoke the TEST from the Utilities Menu screen. The Test Software will display the More screen.

Step 2. If you pressed the **k1 (Test Menu)** key:

1. If testing a Legacy Base Station, select the **Measure Test Cable Loss** field.

If testing a Metro Cell or Rural Cell Base Station, select the **Measure Test Cable and Attenuator Loss** field.

2. Follow the on-screen directions.

If you pressed the **k3 (More)** key:

1. Select the **Utilities** field. The Test Software will display the Utilities Menu screen.
2. Select the **Measure Test Cable Loss** field.
3. Follow the on-screen directions.

Test Descriptions

MFRM Total Output Power Test**CAUTION**

Damage to the Test Set will occur if an external attenuator is not used in this TEST. The total output power of the MFRM Base Station exceeds the power input rating of the Test Set. You must use an external attenuator (such as the 100-watt 10-dB device shown in [Table 3-1 on page 34](#)) to reduce the power applied to the Test Set.

NOTE

This TEST is applicable to MFRM Base Stations only.

This TEST verifies the total output power of all three carriers of the MFRM Base Station. You must use the Vortex to blossom all three carriers to perform this TEST. The digital gain settings of all three carriers should be set to the same required value. (The required settings are explained later in this section.)

This TEST may be initiated from the **Multiple Carrier Test Menu** field on the MFRM Test Menu screen.

The Base Station power output is dependent on the digital gain settings of the pilot channel, paging channel, sync channel, and OCNS channel. It is also dependent upon the number of OCNS channels that are active. Once a Base Station is in service, the gains will be set to optimize the wireless network performance. During testing, there are required gain settings that are more than likely different from the in-service gain settings. These required settings result in a desired Base Station power output, and are as shown in [Table 5-1](#) for IS-95 Base Stations and in [Table 5-2](#) for IS-2000 Base Stations.

Table 5-1 Required Settings for IS-95 Base Stations

Item	MFRM Base Station
Pilot Gain	254
Sync Gain	123
Paging Gain	245
OCNS Nominal Gain	174
Number of OCNS Channels	6

Table 5-2 Required Settings for IS-2000 Base Stations

Item	MFRM Base Station
Pilot Gain	254
Sync Gain	123
Paging Gain	245
OCNS RC3 Fundamental Gain	174
Number of OCNS RC3 Fundamental Channels	5
OCNS RC3 16x Supplemental Gain	174
Number of OCNS Supplemental Channels	1

Ideally, you should change the Base Station gain settings when you test the Base Station. However, this might not always be practical. Therefore, you may use the Digital Gain screen to determine the new Base Station power output based on the gain settings in the Base Station.

You may press the **k4 (Dig Gains)** key to access the Digital Gains screen. If you wish to use different settings, change the **Alternate** fields in this screen (which will cause the Test Software to calculate a new output power value and change the **Base Station Power Out** setting automatically), then select the **Use Alternate Values for Testing** field.

You may use the Vortex PC Power Palette Window to set the digital gains in the Base Station. The digital gain settings reflect the power output of each individual carrier. The total power is the combination of all three individual carriers. If each carrier is set as shown in [Table 5-1](#) or [Table 5-2](#), the total output power is as follows:

- For Metro Cell MFRM 1900-MHz Base Stations, the power is 45.8 dBm with pilot, paging, sync, and 6 OCNS channels active.
- For Metro Cell MFRM 800-MHz Base Stations, the power is 47.3 dBm with pilot, paging, sync, and 6 OCNS channels active.

No Parameters are used in this TEST.

The Pass/Fail Limits used in this TEST are:

- [PASS/FAIL LIMIT 43 — TX Power Loss Combiner Metro 800 MHz](#)
- [PASS/FAIL LIMIT 44 — TX Power Loss IMF Metro Cell 800 MHz](#)
- [PASS/FAIL LIMIT 45 — TX Power Loss LPP & Cable Metro 1900 MHz](#)
- [PASS/FAIL LIMIT 46 — TX Power Loss LPP & Cable Metro 800 MHz](#)

After selecting the Test Suite, invoke and perform this TEST from the Configuration Menu screen as follows:

CAUTION

Before disconnecting any Base Station cables, verify that the site is wilted and is not producing RF power.

- Step 1.** In the **Test Type** field on the Configuration Menu screen, select **Nortel Metro Cell MFRM 1900 MHZ** or **Nortel Metro Cell MFRM 800 MHZ**, as appropriate.
- Step 2.** Press the **k1 (Test Menu)** key. The Test Software will display the Test Menu screen.
- Step 3.** Select the **Multiple Carrier Test Menu** field.
- Step 4.** Select the **MFRM Total Output Power Test** field.
- Step 5.** Follow the on-screen directions.

The following paragraphs provide the upper and lower limit equations for the various types of Base Stations. The definitions for terms used in those equations are as follows:

- UL – Upper pass/fail limit.
- LL – Lower pass/fail limit.
- Power – The setting of the **Base Station Power Out** field on the Configuration Menu screen. This is the basic figure shown on the power meter. It is always present in the equation.
- UL or LL Spec (40) – The basic upper or lower limit for Metro Cell MFRM 1900-MHz Base Stations. It is always present in the equation for those Base Stations.
- UL or LL Spec (41) – The basic upper or lower limit for Metro Cell MFRM 800-MHz Base Stations. It is always present in the equation for those Base Stations.

Test Descriptions

NOTE

The next two items (43 and 44) allow for four combinations of Combiner and IMF: both, IMF, Combiner, neither. Dependent upon the setting of the Configuration Menu screen **TX Conf** field, these items will appear singly, in combination, or not at all.

- UL or LL Spec (43) – The losses associated with an 800-MHz Base Station with a Combiner. It is present for that configuration only. Its presence is determined by the setting of the **TX Conf** field on the Configuration Menu screen.)
- UL or LL Spec (44) – The losses associated with an 800-MHz Base Station with an IMF. It is present for that configuration only. Its presence is determined by the Base Station type and the setting of the **TX Conf** field on the Configuration Menu screen.)
- UL or LL Spec (45) – The loss associated with an LPP and the cables for Metro Cell 1900-MHz Base Stations. It is present in the equation only if the Base Station is an outdoor type. Its presence is determined by the setting of the **Cabinet** field on the Configuration Menu screen.
- UL or LL Spec (46) – The loss associated with an LPP and the cables for Metro Cell 800-MHz or Rural Cell Base Stations. It is present in the equation only if the Base Station is an outdoor type. Its presence is determined by the setting of the **Cabinet** field on the Configuration Menu screen.
- UL or LL Spec (47) – The basic upper or lower limit of power levels < 32 dBm for Metro Cell MFRM 1900-MHz Base Stations. It is always present in the equation for those Base Stations.
- UL or LL Spec (48) – The basic upper or lower limit of power levels < 33 dBm for Metro Cell MFRM 800-MHz Base Stations. It is always present in the equation for those Base Stations.

For indoor Metro Cell MFRM 1900-MHz Base Stations, the upper limit equations are as follows:

$$UL = \text{Power} + UL \text{ Spec (40 or 47)}$$

$$LL = \text{Power} + LL \text{ Spec (40 or 47)}$$

For outdoor Metro Cell MFRM 1900-MHz Base Stations, the upper and lower limit equations are as follows:

$$UL = \text{Power} + UL \text{ Spec (40 or 47)} - LL \text{ Spec (45)}$$

$$LL = \text{Power} + LL \text{ Spec (40 or 47)} - UL \text{ Spec (45)}$$

NOTE

For Metro Cell 800-MHz Base Stations, the specifications shown in italics in the next two paragraphs are optional.

For indoor Metro Cell MFRM 800-MHz Base Stations, the upper and lower limit equations are as follows:

$$UL = \text{Power} + UL \text{ Spec (41 or 48)} - LL \text{ Spec (44)} - LL \text{ Spec (43)}$$

$$LL = \text{Power} + LL \text{ Spec (41 or 48)} - UL \text{ Spec (44)} - UL \text{ Spec (43)}$$

For outdoor Metro Cell MFRM 800-MHz Base Stations, the upper and lower limit equations are as follows:

$$UL = \text{Power} + UL \text{ Spec (41 or 48)} - LL \text{ Spec (46)} - LL \text{ Spec (44)} - LL \text{ Spec (43)}$$

$$LL = \text{Power} + LL \text{ Spec (41 or 48)} - UL \text{ Spec (46)} - UL \text{ Spec (44)} - UL \text{ Spec (43)}$$

OCNS Channels Code Domain Measurements

NOTE

This TEST is applicable to Metro Cell and Rural Cell Base Stations only.

This TEST verifies that the estimated rho, frequency error, time offset, and carrier feedthrough values of the transmitted RF signal from the Base Station are within the prescribed limits.

No Parameters are used in this TEST.

The Pass/Fail Limits used in this TEST are:

- [PASS/FAIL LIMIT 22 — TX Code Domain Carrier Feedthru Metro](#)
- [PASS/FAIL LIMIT 24 — TX Code Domain Frequency Error Metro](#)
- [PASS/FAIL LIMIT 26 — RX Code Domain Rho Metro Cell](#)
- [PASS/FAIL LIMIT 28 — TX Code Domain Time Offset Metro Cell](#)
- [PASS/FAIL LIMIT 29 — TX Code Domain Time Offset w/IMF or Comb](#)

After selecting the Test Suite, invoke and perform this TEST from the Configuration Menu screen as follows:

CAUTION

Before disconnecting any Base Station cables, verify that the site is wilted and is not producing RF power.

- Step 1.** Press the **k1 (Test Menu)** key. The Test Software will display the Test Menu screen.
- Step 2.** Select the **OCNS Channels Code Domain Measurements** field.
- Step 3.** Follow the on-screen directions. (See [“Blossoming the Base Station”](#) on page 92 for detailed information on channels and gains.)

Pilot Only Check

NOTE

This TEST is applicable to Legacy Base Stations only.

This TEST verifies that the Base Station is transmitting on Walsh code channel 0. All other code channels should be below the threshold line on the display.

No Parameters are used in this TEST.

One Pass/Fail Limit is used in this TEST. It is:

- [PASS/FAIL LIMIT 31 — TX Inactive Code Channel Maximum Level](#)

After selecting the Test Suite, invoke and perform this TEST from the Configuration Menu screen as follows:

CAUTION

Before disconnecting any Base Station cables, verify that the site is wilted and is not producing RF power.

Step 1. Press the **k1 (Test Menu)** key. The Test Software will display the Test Menu screen.

Step 2. Select the **Pilot Only Check** field.

Step 3. Follow the on-screen directions. (See [“Blossoming the Base Station”](#) on page 92 for detailed information on channels and gains.)

RX0 Receive FER Test

NOTE

This TEST is applicable to Metro Cell and Rural Cell Base Stations only.

This TEST does not operate with all versions of Vortex. Contact Nortel to determine the required version.

This TEST is used in conjunction with the Vortex to measure the reverse channel frame (FER) of the Base Station. The TEST injects a CDMA reverse link signal into the Base Station receiver. The Vortex then reports the percentage of frame error rate of the CDMA signal. The initial RF level of the CDMA signal is determined by [PARAMETER 6 — RX RF Level for Frame Error Rate \(FER\)](#).

The RF level may be adjusted in the TEST for troubleshooting. Increasing the level will improve the FER; decreasing the level will degrade the FER.

The Test Software will prompt you to enter the %FER from the Vortex in order to compare the value with [PASS/FAIL LIMIT 1 — RX Frame Error Rate \(FER\)](#).

NOTE

Setting up the Vortex to report FER is somewhat complicated. The Test Software will supply prompts for the setup. If you require further assistance, refer to the Installation Method from Nortel.

One Parameter is used in this TEST. It is:

- [PASS/FAIL LIMIT 6 — RX Gain Metro 1900 MHz thru No TRM](#)

One Pass/Fail Limit is used in this TEST. It is:

- [PASS/FAIL LIMIT 1 — RX Frame Error Rate \(FER\)](#)

After selecting the Test Suite, invoke and perform this TEST from the Configuration Menu screen as follows:

CAUTION

Before disconnecting any Base Station cables, verify that the site is wilted and is not producing RF power.

- Step 1.** From the Configuration Menu screen, press the **k1 (Test Menu)** key. The Test Software will display the Test Menu screen.
- Step 2.** Select the **RX0 Receive FER Test** field.
- Step 3.** Follow the on-screen directions. (See [“Blossoming the Base Station”](#) on page 92 for detailed information on channels and gains.)

Test Descriptions

RX1 Receive FER Test

This TEST is the same as the RX0 Receive FER Test, except that it applies to the RX1 receiver.

In this Test, select the **RX1 Receive FER Test** field in step 2.

RX0 Receive Power Test

NOTE

This TEST is applicable to Metro Cell and Rural Cell Base Stations only.

This TEST verifies the difference between the receive power reported by the Base Station Maintenance Unit (BMU) or the Vortex with no signal present and receive power reported when a -90-dBm signal is injected into the RX0 receiver. The measurement, which is a measure of the increase in receive power, is compared with the setting of [PASS/FAIL LIMIT 18 — RX Power Gain Metro Cell](#).

A high-power attenuator is not required on the RF IN/OUT port of the Test Set for the Rural Cell Base Station because the transmitter output is not present at the DPM antenna output.

One Parameter is used in this TEST. It is:

- [PARAMETER 7 — RX RF Level for RX Power Test](#)

One Pass/Fail Limit is used in this TEST. It is:

- [PASS/FAIL LIMIT 18 — RX Power Gain Metro Cell](#)

After selecting the Test Suite, invoke and perform this TEST from the Configuration Menu screen as follows:

CAUTION

Before disconnecting any Base Station cables, verify that the site is wilted and is not producing RF power.

- Step 1.** From the Configuration Menu screen, press the **k1 (Test Menu)** key. The Test Software will display the Test Menu screen.
- Step 2.** Select the **RX0 Receive Power Test** field.
- Step 3.** Follow the on-screen directions. (See [“Blossoming the Base Station” on page 92](#) for detailed information on channels and gains.)

Test Descriptions

RX1 Receive Power Test

This TEST is the same as the RX0 Receive Power Test, except that it applies to the RX1 receiver.

In this Test, select the **RX1 Receive Power Test** field in step 2.

Receive Path Verification, RX0 Receive Path Gain, RX1 Receive Path Gain

NOTE

The Receive Path Verification Test checks the gain through both receivers, and is applicable to all Legacy Base Stations. The RX0 Receive Path Gain Test checks the gain through only receiver RX0. The RX1 Receive Path Gain Test checks the gain through only receiver RX1. The RX0 and RX1 Tests are applicable to Metro Cell and Rural Cell Base Stations.

This TEST verifies that all components in the receive path are operating within prescribed limits for amplification and attenuation.

No Parameters are used in this TEST.

The Pass/Fail Limits used in this TEST are:

- [PASS/FAIL LIMIT 2 — RX Gain 1900 MHz](#)
- [PASS/FAIL LIMIT 3 — RX Gain C800](#)
- [PASS/FAIL LIMIT 4 — RX Gain FCP800](#)
- [PASS/FAIL LIMIT 5 — RX Gain Macro](#)
- [PASS/FAIL LIMIT 6 — RX Gain Metro 1900 MHz thru No TRM](#)
- [PASS/FAIL LIMIT 7 — RX Gain Metro 1900 MHz thru One TRM](#)
- [PASS/FAIL LIMIT 8 — RX Gain Metro 1900 MHz thru Three TRMs](#)
- [PASS/FAIL LIMIT 9 — RX Gain Metro 1900 MHz thru Two TRMs](#)
- [PASS/FAIL LIMIT 10 — RX Gain Metro 800 MHz Div thru One TRM](#)
- [PASS/FAIL LIMIT 11 — RX Gain Metro 800 MHz Div thru No TRM](#)
- [PASS/FAIL LIMIT 12 — RX Loss 1:2 Splitter Metro 1900 MHz](#)
- [PASS/FAIL LIMIT 13 — RX Loss 1:2 Splitter Metro 800 MHz](#)
- [PASS/FAIL LIMIT 14 — RX Loss 1:4 Splitter Metro 800 MHz](#)
- [PASS/FAIL LIMIT 15 — RX Loss 1:6 Splitter Metro 800 MHz](#)
- [PASS/FAIL LIMIT 16 — RX Loss LPP and Cable Metro 800/1900 MHz](#)
- [PASS/FAIL LIMIT 17 — RX Loss TRM Splitter Metro 1900 MHz](#)

After selecting the Test Suite, invoke and perform this TEST from the Configuration Menu screen as follows:

CAUTION

Before disconnecting any Base Station cables, verify that the site is wilted and is not producing RF power.

Test Descriptions

- Step 1.** Press the **k1 (Test Menu)** key. The Test Software will display the Test Menu screen.
- Step 2.** Select the **Receiver Path Verification** field, **RX0 Receive Path Gain** field, or **RX1 Receive Path Gain** field, as applicable to the TEST, from the Test Menu screen.
- Step 3.** Follow the on-screen directions. (See [“Blossoming the Base Station” on page 92](#) for detailed information on channels and gains.)

The following paragraphs provide the upper and lower limit equations for the various types of Base Stations. The definitions for terms used in those equations are as follows:

- UL – Upper pass/fail limit
- LL – Lower pass/fail limit.
- UL or LL Spec (6) – The upper or lower limit for Metro Cell 1900-MHz Base Station gain from the DPM input to the cable connected to the RX0/RX1 input of the TRM.
- UL or LL Spec (7) – The upper or lower limit for Metro Cell 1900-MHz Base Station gain from the DPM input through one TRM to the RX0/RX1 output of the TRM.
- UL or LL Spec (8) – The upper or lower limit for Metro Cell 1900-MHz Base Station gain from the DPM input through three TRMs to the RX0/RX1 output of the third TRM.
- UL or LL Spec (9) – The upper or lower limit for Metro Cell 1900-MHz Base Station gain from the DPM input through two TRMs to the RX0/RX1 output of the second TRM.
- UL or LL Spec (10) – The upper or lower limit for Metro Cell 800-MHz or Rural Cell Base Station gain from the DPM input thorough one TRM to the RX0/RX1 output of the TRM.
- UL or LL Spec (11) – The upper or lower limit for Metro Cell 800-MHz or Rural Cell Base Station gain from the DPM input through the cable connected to the RX0/RX1 input of the TRM.
- UL or LL Spec (12) – The upper or lower limit for the external 1:2 splitter in the Metro Cell 1900-MHz Base Station.
- UL or LL Spec (13) – The upper or lower limit for the external 1:2 splitter in the Metro Cell 800-MHz Base Station.
- UL or LL Spec (14) – The upper or lower limit for losses through the 1:4 external splitter for Metro Cell 800-MHz or Rural Cell Base Stations.
- UL or LL Spec (15) – The upper or lower limit for losses through the 1:6 external splitter for Metro Cell 800-MHz or Rural Cell Base Stations.
- UL or LL Spec (16) – The upper or lower limit for losses of the LPP and cables for 800-MHz and Metro Cell 1900-MHz Base Stations.
- UL or LL Spec (17) – The upper or lower limit for the TRM splitter in the Metro Cell 1900-MHz Base Station.

For Legacy Base Stations, the upper and lower pass/fail limits are contained in one specification for each type of Base Station as follows:

- 1900-MHz Base Stations:
 - UL = UL Spec (2)
 - LL = LL Spec (2)

- C800 Base Stations:
 - UL = UL Spec (3)
 - LL = LL Spec (3)
- FCP800 Base Stations:
 - UL = UL Spec (4)
 - LL = LL Spec (4)
- Macro Base Stations:
 - UL = UL Spec (5)
 - LL = LL Spec (5)

For indoor Metro Cell 800-MHz or Rural Cell Base Stations, the upper and lower limit equations for gain in dB from the DPM to the cable connected to the TRM RX0/RX1 input are as follows:

- No External Splitter (1 Carrier):
 - UL = UL Spec (11)
 - LL = LL Spec (11)
- No External Splitter (2 Carriers):
 - UL = UL Spec (10)
 - LL = LL Spec (10)
- 1:4 External Splitter (All Carriers):
 - UL = UL Spec (11) – LL Spec (14)
 - LL = LL Spec (11) – UL Spec (14)
- 1:6 External Splitter (All Carriers):
 - UL = UL Spec (11) – LL spec (15)
 - LL = LL Spec (11) – UL spec (15)

For outdoor Metro Cell 800-MHz or Rural Cell Base Stations, the upper and lower limit equations for gain in dB from the LPP to the cable connected to the TRM RX0/RX1 input are as follows:

- No External Splitter (1 Carrier):
 - UL = UL Spec (11) – LL Spec (16)
 - LL = LL Spec (11) – UL Spec (16)
- No External Splitter (2 Carriers):
 - UL = UL Spec (10) – LL Spec (16)
 - LL = LL Spec (10) – UL Spec (16)
- 1:4 External Splitter (All Carriers):
 - UL = UL Spec (11) – LL Spec (14) - LL Spec (16)
 - LL = LL Spec (11) – UL Spec (14) - UL Spec (16)

Test Descriptions

- 1:6 External Splitter (All Carriers):

$$UL = UL \text{ Spec (11)} - LL \text{ spec (15)} - LL \text{ Spec (16)}$$

$$LL = LL \text{ Spec (11)} - UL \text{ spec (15)} - UL \text{ Spec (16)}$$

For indoor Metro Cell 1900-MHz Base Stations, the upper and lower limit equations for RX0 gain in dB from the DPM to the TRM splitter RX0 output are as follows:

- All Carriers:

$$UL = UL \text{ Spec (7)}$$

$$LL = LL \text{ Spec (7)}$$

For outdoor Metro Cell 1900-MHz Base Stations, the upper and lower limit equations for RX0 gain in dB from the LPP to the TRM splitter RX0 output are as follows:

- All Carriers:

$$UL = UL \text{ Spec (7)} - LL \text{ Spec (16)}$$

$$LL = LL \text{ Spec (7)} - UL \text{ Spec (16)}$$

For indoor Metro Cell 1900-MHz Base Stations, the upper and lower limit equations for RX1 gain in dB from the DPM to the TRM splitter RX1 output are as follows:

- 1 Carrier:

$$UL = UL \text{ Spec (7)}$$

$$LL = LL \text{ Spec (7)}$$

- 2 Carriers, 3 Carriers (1st and 2nd), or 4 Carriers (1st and 2nd):

$$UL = UL \text{ Spec (9)}$$

$$LL = LL \text{ Spec (9)}$$

- 3 Carriers (3rd), or 4 Carriers (3rd and 4th):

$$UL = UL \text{ Spec (8)}$$

$$LL = LL \text{ Spec (8)}$$

For outdoor Metro Cell 1900-MHz Base Stations, the upper and lower limit equations for RX1 gain in dB from the LPP to the TRM splitter RX1 output are as follows:

- 1 Carrier:

$$UL = UL \text{ Spec (7)} - LL \text{ Spec (16)}$$

$$LL = LL \text{ Spec (7)} - UL \text{ Spec (16)}$$

- 2 Carriers, 3 Carriers (1st and 2nd), or 4 Carriers (1st and 2nd):

$$UL = UL \text{ Spec (9)} - LL \text{ Spec (16)}$$

$$LL = LL \text{ Spec (9)} - UL \text{ Spec (16)}$$

- 3 Carriers (3rd), or 4 Carriers (3rd and 4th):

$$UL = UL \text{ Spec (8)} - LL \text{ Spec (16)}$$

$$LL = LL \text{ Spec (8)} - UL \text{ Spec (16)}$$

For indoor MFRM Metro Cell 1900-MHz Base Stations, the upper and lower limit equations are as follows:

$$UL = UL \text{ Spec (6)} - LL \text{ Spec (12) and/or LL Spec (17)}$$

$$LL = LL \text{ Spec (6)} - UL \text{ Spec (12) and/or UL Spec (17)}$$

For outdoor MFRM Metro Cell 1900-MHz Base Stations, the upper and lower limit equations are as follows:

$$UL = UL \text{ Spec (6)} - LL \text{ Spec (16)} - LL \text{ Spec (12) and/or LL Spec (17)}$$

$$LL = LL \text{ Spec (6)} - UL \text{ Spec (16)} - UL \text{ Spec (12) and/or UL Spec (17)}$$

For indoor MFRM Metro Cell 800-MHz Base Stations, the upper and lower limit equations are as follows:

$$UL = UL \text{ Spec (11)} - LL \text{ Spec (13), or LL Spec (14), or LL Spec (15)}$$

(Use of Spec 13, 14, or 15 is dependent upon the setting of the **RX Conf** field on the Configuration screen.)

$$LL = LL \text{ Spec (11)} - UL \text{ Spec (13), or UL Spec (14), or UL Spec (15)}$$

(Use of Spec 13, 14, or 15 is dependent upon the setting of the **RX Conf** field on the Configuration screen.)

For outdoor MFRM Metro Cell 800-MHz Base Stations, the upper and lower limit equations are as follows:

$$UL = UL \text{ Spec (11)} - LL \text{ Spec (16)} - LL \text{ Spec (13), or LL Spec (14), or LL Spec (15)}$$

(Use of Spec 13, 14, or 15 is dependent upon the setting of the **RX Conf** field on the Configuration screen.)

$$LL = LL \text{ Spec (11)} - UL \text{ Spec (16)} - UL \text{ Spec (13), or UL Spec (14), or UL Spec (15)}$$

(Use of Spec 13, 14, or 15 is dependent upon the setting of the **RX Conf** field on the Configuration screen.)

RF Power Sensor Verification, HIP-D Power Sensor Verification, or MCPA RMS Power Sensor Verification

NOTE

For Legacy Base Stations, this TEST is called RF Power Sensor Verification.

For SFRM Metro Cell or Rural Cell Base Stations, this TEST is called HIP-D Power Sensor Verification.

For MFRM Metro Cell Base Stations, this TEST is called MCPA RMS Power Sensor Verification.

When testing MFRM Base Stations, this test should be used only for testing a single carrier. If you wish to test all three carriers, use the MFRM Total Output Power Test.

This TEST verifies that the accuracy of the Base Station RF power sensor is within specified limits.

The Base Station power output is dependent on the digital gain settings of the pilot channel, paging channel, sync channel, and OCNS channel. It is also dependent upon the number of OCNS channels that are active. Once a Base Station is in service, the gains will be set to optimize the wireless network performance. During testing, there are recommended gain settings that are more than likely different than the in-service gain settings. These recommended settings result in a desired Base Station power output, and are as shown in [Table 5-3](#).

Table 5-3 Recommended Settings

Item	Legacy Base Station	IS-95 Metro Cell or Rural Cell Base Station	IS-2000 Metro Cell or Rural Cell Base Station
Pilot Gain	254	254	254
Sync Gain	0	123	123
Paging Gain	0	245	245
OCNS Nominal Gain	0	174	174
Number of OCNS Channels	0	6	NA
OCNS RC3 Fundamental Gain	NA	NA	174
Number of OCNS RC3 Fundamental Channels	NA	NA	5
OCNS RC 3 16x Supplemental Gain	NA	NA	174
Number of OCNS Supplemental Channels	NA	NA	1

Ideally, you should change the Base Station gain settings when you test the Base Station. However, this might not always be practical. Therefore, you may use the Digital Gain screen to determine the new Base Station power output based on the gain settings in the Base Station.

You may press the **k4 (Dig Gains)** key to access the Digital Gains screen. If you wish to use different settings, change the **Alternate** fields in this screen (which will cause the Test Software to calculate a new output power value and change the **Base Station Power Out** setting automatically), then select the **Use Alternate Values for Testing** field.

You may use the Vortex PC Power Palette Window to set the digital gains in the Base Station.

Based on the settings as shown in the table, the output powers are as follows:

- For Legacy Base Stations, the output is 4 watts with only the pilot Walsh code active.
- For Metro Cell 1900-MHz Base Stations, the power is 41 dBm with pilot, paging, sync, and 6 OCNS channels active.
- For Metro Cell 800-MHz Base Stations, the power is 42.5 dBm with pilot, paging, sync, and 6 OCNS channels active.
- For Rural Cell Base Stations, the power is 49.2 dBm with pilot, paging, sync, and 6 OCNS channels active.

NOTE

The calibration of the Legacy 1900-MHz Base Stations is influenced by the ambient temperature of the Base Station, RFFE, PSC drivers, and the upconverters. Thus, the ambient temperature **MUST** be recorded as part of this procedure if you are testing a Legacy 1900-MHz Base Station. (The temperature must be set so as to use the correct specification limits by pressing the **k5 (More)** key from the power display screen and entering the temperature.)

The Test Set is also affected by temperature. If the Test Set is moved from a sheltered environment to an exposed one, it must be allowed to reach thermal equilibrium (even if it has not been unplugged from the power source). This will require 30 minutes.

No Parameters are used in this TEST.

The Pass/Fail Limits used in this TEST are:

- [PASS/FAIL LIMIT 33 — TX Power Error 1900 MHz](#)
- [PASS/FAIL LIMIT 34 — TX Power Error at Temp Extremes 1900 MHz](#)
- [PASS/FAIL LIMIT 35 — TX Power Error C800](#)
- [PASS/FAIL LIMIT 36 — TX Power Error FCP800](#)
- [PASS/FAIL LIMIT 37 — RX Power Error Macro](#)
- [PASS/FAIL LIMIT 38 — TX Power Error Metro Cell 1900 MHz](#)
- [PASS/FAIL LIMIT 39 — TX Power Error Metro Cell 800 MHz](#)
- [PASS/FAIL LIMIT 40 — TX Power Error Metro Cell MFRM 1900 MHz](#)
- [PASS/FAIL LIMIT 41 — TX Power Error Metro Cell MFRM 800 MHz](#)
- [PASS/FAIL LIMIT 42 — TX Power Error Rural Cell 800 MHz](#)
- [PASS/FAIL LIMIT 43 — TX Power Loss Combiner Metro 800 MHz](#)
- [PASS/FAIL LIMIT 44 — TX Power Loss IMF Metro Cell 800 MHz](#)
- [PASS/FAIL LIMIT 45 — TX Power Loss LPP & Cable Metro 1900 MHz](#)
- [PASS/FAIL LIMIT 46 — TX Power Loss LPP & Cable Metro 800 MHz](#)
- [PASS/FAIL LIMIT 47 — TX Power Error MFRM 1900 MHz <32 dBm](#)
- [PASS/FAIL LIMIT 48 — TX Power Error MFRM 800 MHz <33 dBm](#)

Test Descriptions

After selecting the Test Suite, invoke and perform this TEST from the Configuration Menu screen as follows:

CAUTION

Before disconnecting any Base Station cables, verify that the site is wilted and is not producing RF power.

Step 1. Press the **k1 (Test Menu)** key. The Test Software will display the Test Menu screen.

Step 2. If testing a Legacy Base Station, select the **RF Power Sensor Path Verification** field.

If testing a Metro Cell or Rural Cell Base Station select the **HIP-D Power Sensor Verification** field.

Step 3. Follow the on-screen directions. (See [“Blossoming the Base Station” on page 92](#) for detailed information on channels and gains.)

The following paragraphs provide the upper and lower limit equations for the various types of Base Stations. The definitions for terms used in those equations are as follows:

- UL – Upper pass/fail limit.
- LL – Lower pass/fail limit.
- Power – The setting of the **Base Station Power Out** field on the Configuration Menu screen. This is the basic figure shown on the power meter. It is always present in the equation.
- UL or LL Spec (33) – The basic upper or lower limit for 1900-MHz Base Stations at temperatures between 50° F and 85° F. Its presence in the equation is determined by the temperature setting recorded after pressing the **k5 (More)** key from the power display screen and entering the temperature.
- UL or LL Spec (34) – The basic upper or lower limit for 1900-MHz Base Stations at temperatures below 50° F or above 85° F. Its presence in the equation is determined by the temperature setting recorded after pressing the **k5 (More)** key from the power display screen and entering the temperature.
- UL or LL Spec (35) – The basic upper or lower limit for C800-MHz Base Stations. It is always present in the equation for those Base Stations.
- UL or LL Spec (36) – The basic upper or lower limit for FCP800-MHz Base Stations. It is always present in the equation for those Base Stations.
- UL or LL Spec (37) – The basic upper or lower limit for Macro Base Stations. It is always present in the equation for those Base Stations.
- UL or LL Spec (38) – The basic upper or lower limit for Metro Cell 1900-MHz Base Stations. It is always present in the equation for those Base Stations.
- UL or LL Spec (39) – The basic upper or lower limit for Metro Cell 800-MHz Base Stations. It is always present in the equation for those Base Stations.
- UL or LL Spec (40) – The basic upper or lower limit of power levels ≥ 32 dBm for Metro Cell MFRM 1900-MHz Base Stations. It is always present in the equation for those Base Stations.
- UL or LL Spec (41) – The basic upper or lower limit of power levels ≥ 33 dBm for Metro Cell MFRM 800-MHz Base Stations. It is always present in the equation for those Base Stations.

- UL or LL Spec (42) – The basic upper or lower limit for Rural Cell Base Stations. It is always present in the equation for those Base Stations.

NOTE

The next two items (43 and 44) allow for four combinations of Combiner and IMF. These are: neither, IMF, Combiner, both. Dependent upon the setting of the **TX Conf** field on the Configuration Menu screen, these items will appear singly, in combination, or not at all.

- UL or LL Spec (43) – The losses associated with an 800-MHz Base Station with a Combiner. It is present for that configuration only. Its presence is determined by the setting of the **TX Conf** field on the Configuration Menu screen.)
- UL or LL Spec (44) – The losses associated with an 800-MHz Base Station with an IMF. It is present for that configuration only. Its presence is determined by the Base Station type and the setting of the **TX Conf** field on the Configuration Menu screen.)
- UL or LL Spec (45) – The loss associated with an LPP and the cables for Metro Cell 1900-MHz Base Stations. It is present in the equation only if the Base Station is an outdoor type. Its presence is determined by the setting of the **Cabinet** field on the Configuration Menu screen.
- UL or LL Spec (46) – The loss associated with an LPP and the cables for Metro Cell 800-MHz or Rural Cell Base Stations. It is present in the equation only if the Base Station is an outdoor type. Its presence is determined by the setting of the **Cabinet** field on the Configuration Menu screen.
- UL or LL Spec (47) – The basic upper or lower limit of power levels < 32 dBm for Metro Cell MFRM 1900-MHz Base Stations. It is always present in the equation for those Base Stations.
- UL or LL Spec (48) – The basic upper or lower limit of power levels < 33 dBm for Metro Cell MFRM 800-MHz Base Stations. It is always present in the equation for those Base Stations.

For indoor Metro Cell 1900-MHz Base Stations, the upper limit equations are as follows:

$$\text{UL} = \text{Power} + \text{UL Spec (38)}$$

$$\text{LL} = \text{Power} + \text{LL Spec (38)}$$

For outdoor Metro Cell 1900-MHz Base Stations, the upper and lower limit equations are as follows:

$$\text{UL} = \text{Power} + \text{UL Spec (38)} - \text{LL Spec (45)}$$

$$\text{LL} = \text{Power} + \text{LL Spec (38)} - \text{UL Spec (45)}$$

For indoor Metro Cell MFRM 1900-MHz Base Stations, the upper limit equations are as follows:

$$\text{UL} = \text{Power} + \text{UL Spec (40 or 47)}$$

$$\text{LL} = \text{Power} + \text{LL Spec (40 or 47)}$$

For outdoor Metro Cell MFRM 1900-MHz Base Stations, the upper and lower limit equations are as follows:

$$\text{UL} = \text{Power} + \text{UL Spec (40 or 47)} - \text{LL Spec (45)}$$

$$\text{LL} = \text{Power} + \text{LL Spec (40 or 47)} - \text{UL Spec (45)}$$

Test Descriptions

NOTE

For Metro Cell 800-MHz or Rural Cell Base Stations, the specifications shown in italics in the next six paragraphs are optional.

For indoor Metro Cell 800-MHz Base Stations, the upper and lower limit equations are as follows:

$$UL = \text{Power} + UL \text{ Spec } (39) - LL \text{ Spec } (44) - LL \text{ Spec } (43)$$

$$LL = \text{Power} + LL \text{ Spec } (39) - UL \text{ Spec } (44) - UL \text{ Spec } (43)$$

For outdoor Metro Cell 800-MHz Base Stations, the upper and lower limit equations are as follows:

$$UL = \text{Power} + UL \text{ Spec } (39) - LL \text{ Spec } (46) - LL \text{ Spec } (44) - LL \text{ Spec } (43)$$

$$LL = \text{Power} + LL \text{ Spec } (39) - UL \text{ Spec } (46) - UL \text{ Spec } (44) - UL \text{ Spec } (43)$$

For indoor Metro Cell MFRM 800-MHz Base Stations, the upper and lower limit equations are as follows:

$$UL = \text{Power} + UL \text{ Spec } (41 \text{ or } 48) - LL \text{ Spec } (44) - LL \text{ Spec } (43)$$

$$LL = \text{Power} + LL \text{ Spec } (41 \text{ or } 48) - UL \text{ Spec } (44) - UL \text{ Spec } (43)$$

For outdoor Metro Cell MFRM 800-MHz Base Stations, the upper and lower limit equations are as follows:

$$UL = \text{Power} + UL \text{ Spec } (41 \text{ or } 48) - LL \text{ Spec } (46) - LL \text{ Spec } (44) - LL \text{ Spec } (43)$$

$$LL = \text{Power} + LL \text{ Spec } (41 \text{ or } 48) - UL \text{ Spec } (46) - UL \text{ Spec } (44) - UL \text{ Spec } (43)$$

For indoor Rural Cell Base Stations, the upper limit equations are as follows:

$$UL = \text{Power} + UL \text{ Spec } (42) - LL \text{ Spec } (44) - LL \text{ Spec } (43)$$

$$LL = \text{Power} + LL \text{ Spec } (42) - UL \text{ Spec } (44) - UL \text{ Spec } (43)$$

For outdoor Rural Cell Base Stations, the upper and lower limit equations are as follows:

$$UL = \text{Power} + UL \text{ Spec } (42) - LL \text{ Spec } (46) - LL \text{ Spec } (44) - LL \text{ Spec } (43)$$

$$LL = \text{Power} + LL \text{ Spec } (42) - UL \text{ Spec } (46) - UL \text{ Spec } (44) - UL \text{ Spec } (43)$$

For Legacy 1900-MHz Base Stations, the upper and lower limit equations are as follows:

$$UL = \text{Power} + UL \text{ Spec } (33 \text{ or } 34)$$

$$LL = \text{Power} + LL \text{ Spec } (33 \text{ or } 34)$$

For Legacy C800-MHz Base Stations, the upper and lower limit equations are as follows:

$$UL = \text{Power} + UL \text{ Spec } (35)$$

$$LL = \text{Power} + LL \text{ Spec } (35)$$

For Legacy FCP 800-MHz Base Stations, the upper and lower limit equations are as follows:

$$UL = \text{Power} + UL \text{ Spec } (36)$$

$$LL = \text{Power} + LL \text{ Spec } (36)$$

For Legacy Macro Base Stations, the upper and lower limit equations are as follows:

$$UL = \text{Power} + UL \text{ Spec } (37)$$

$$LL = \text{Power} + LL \text{ Spec } (37)$$

Spectral Interference Evaluation

This TEST verifies that there are no interfering signals on either the forward or reverse link channels.

This TEST provides for the use of an optional LNA for evaluating low-level signals that might interfere with the CDMA channel. To set the Test Software to use an external LNA, select the **More** field from the Configuration Menu screen, then select the **Use LNA for Spec Interfer** field on the More screen. Following that selection, the Test Software will include the LNA in each appropriate connection diagram. Press the **k5 (Return)** key to return to the Configuration Menu screen.

NOTE

The Code Domain Analyzer Test Function of the Test Set operates outside of the Test Software. Invoking the analyzer pauses the Test Software in its current state.

No Parameters are used in this TEST.

No Pass/Fail Limits are used in this TEST.

After selecting the Test Suite, invoke and perform this TEST from the Configuration Menu screen as follows:

CAUTION

Before disconnecting any Base Station cables, verify that the site is wilted and is not producing RF power.

- Step 1.** Press the **k1 (Test Menu)** key. The Test Software will display the Test Menu screen.
- Step 2.** Select the **Spectral Interference Evaluation** field from the Test Menu screen. The Test Software will display the Spectral Interference Evaluation Menu screen.
- Step 3.** Select the **Analyze Forward Link Channel** field, the **Analyze Reverse Link Channel** field, or the **Analyze Diversity Reverse Link Channel** field, as appropriate.
- Step 4.** Follow the on-screen directions.

Spectral Regrowth Test

NOTE

This TEST may be invoked from either the Test Menu screen or the Utilities Menu screen.

This TEST verifies that the Base Station is within its 1.23-MHz bandwidth and is not generating any undesired out-of-channel power.

No Parameters are used in this TEST.

The Pass/Fail Limits used in this TEST are:

- [PASS/FAIL LIMIT 19 — TX Adjacent Channel Pow at 750 kHz Offsets](#)
- [PASS/FAIL LIMIT 20 — TX Adjacent Channel Pow at 885 kHz Offsets](#)

After selecting the Test Suite, invoke and perform this TEST from the Configuration Menu screen or the Utilities Menu screen as follows:

CAUTION

Before disconnecting any Base Station cables, verify that the site is wilted and is not producing RF power.

Step 1. Either:

Press the **k1 (Test Menu)** key if you wish to invoke the TEST from the Test Menu screen. The Test Software will display the Test Menu screen.

or

Press the **k3 (Utilities)** key if you wish to invoke the TEST from the Utilities screen. The Test Software will display the Utilities screen.

Step 2. If you pressed the **k1 (Test Menu)** key:

1. Select the **Spectral Regrowth Test** field from the Test Menu screen.
2. Follow the on-screen directions. (See [“Blossoming the Base Station” on page 92](#) for detailed information on channels and gains.)

If you pressed the **k3 (Utilities)** key:

1. Select the **Spectral Regrowth Test** field from the Utilities screen.
2. Follow the on-screen directions. (See [“Blossoming the Base Station” on page 92](#) for detailed information on channels and gains.)

Spurious Emission Test

The spurious emissions measurement consists of three sections: in-band emissions, 1 MHz adjacent block, and out-of-band emissions. These are described in the following sub-sections.

In-Band Emissions

This test measures the spurious emissions within a single PCS block. The PCS block to be tested is determined by the channel number entered on the Base Station Configuration Menu screen. The test measures the emissions power starting 900 kHz below the CDMA carrier to the bottom end of the PCS block in 30-kHz steps and starting 900 kHz above the CDMA carrier to the top end of the PCS block in 30-kHz steps. A 30-kHz measurement bandwidth is used for each step. The emissions power in each measurement step should be less than -45 dBc.

1 MHz Adjacent Block

This test measures the spurious emissions 1 MHz outside of the PCS block tested during the In-Band Emissions Test. The test measures the emissions power starting 1 MHz below the bottom edge of the PCS block up to the block edge in 12.5-kHz steps and from the top end of the PCS block to 1 MHz above the top of the block in 12.5-kHz steps. A 12.5-kHz measurement bandwidth is used for each step. The emissions power in each measurement step should be less than -13 dBm.

Out-of-Band Emissions

This test measures the spurious emissions from 1700 MHz to 2000 MHz in 1-MHz steps excluding the PCS block tested during the In-Band Emissions Test. A 1-MHz measurement bandwidth is used for each step. The emissions power in each measurement step should be less than -13 dBm.

No Parameters are used in this TEST.

No Pass/Fail Limits are used in this TEST.

Invoke and perform this TEST from the Configuration Menu screen as follows:

CAUTION

Before disconnecting any Base Station cables, verify that the site is wilted and is not producing RF power.

- Step 1.** Select the **Utilities** field. The Test Software will display the Utilities Menu screen.
- Step 2.** Select the **Spurious Emission Test** field.
- Step 3.** After following the on-screen directions to operate the Test Function, press the **Pause/Continue** key to return to the Test Software at the Test Menu screen. (See [“Blossoming the Base Station” on page 92](#) for detailed information on channels and gains.)

Test Set Calibration and PAM Warm-Up

NOTE

This TEST is applicable to Metro Cell and Rural Cell Base Stations only.

This TEST serves two purposes: The first is to provide a convenient point to calibrate the power meters in the Test Set. The second is to allow adequate time for the Base Station Power Amplifier to stabilize before making power measurements.

In order to calibrate the power meters in the Test Set, no external RF signal should be connected. If this test is performed at the start of the test sequence, before cables are connected to the Base Station, the Test Software will not prompt you later in the other tests to remove cables to calibrate.

After calibration, the Test Software will prompt you to blossom the Base Station and wait for the RF signal to stabilize. A spectrum analyzer mask will indicate the valid range of the RF signal.

No Parameters are used in this TEST.

The Pass/Fail Limits used in this TEST are:

- [PASS/FAIL LIMIT 38 — TX Power Error Metro Cell 1900 MHz](#)
- [PASS/FAIL LIMIT 39 — TX Power Error Metro Cell 800 MHz](#)
- [PASS/FAIL LIMIT 40 — TX Power Error Metro Cell MFRM 1900 MHz](#)
- [PASS/FAIL LIMIT 41 — TX Power Error Metro Cell MFRM 800 MHz](#)
- [PASS/FAIL LIMIT 42 — TX Power Error Rural Cell 800 MHz](#)
- [PASS/FAIL LIMIT 43 — TX Power Loss Combiner Metro 800 MHz](#)
- [PASS/FAIL LIMIT 44 — TX Power Loss IMF Metro Cell 800 MHz](#)
- [PASS/FAIL LIMIT 44 — TX Power Loss IMF Metro Cell 800 MHz](#)
- [PASS/FAIL LIMIT 46 — TX Power Loss LPP & Cable Metro 800 MHz](#)

After selecting the Test Suite, invoke and perform this TEST from the Configuration Menu screen as follows:

CAUTION

Before disconnecting any Base Station cables, verify that the site is wilted and is not producing RF power.

Step 1. Press the **k1 (Test Menu)** key. The Test Software will display the Test Menu screen.

Step 2. Select the **Test Set Calibration and PAM Warm-Up** field.

Step 3. Follow the on-screen directions. (See [“Blossoming the Base Station” on page 92](#) for detailed information on channels and gains.)

Test Suite Descriptions

Each Test Suite is a group of TESTs. Each TEST may include one measurement or a series of measurements, and each TEST is performed singly.

The Test Software offers the following Test Suites. The TESTs in these suites are derived from the Nortel Installation Methods.

- Test Suite 0 – Nortel CDMA 1900 MHz Install
- Test Suite 1 – CDMA 1900 MHz Install
- Test Suite 2 – Nortel CDMA C800 Install
- Test Suite 3 – CDMA C800 Install
- Test Suite 4 – Nortel CDMA Macro Install
- Test Suite 5 – CDMA Macro Install
- Test Suite 6 – Nortel CDMA FCP800 Install
- Test Suite 7 – CDMA FCP800 Install
- Test Suite 8 – Nortel Metro Cell 1900 MHz Install
- Test Suite 9 – Nortel Metro Cell 800 MHz Install
- Test Suite 10 – Nortel Rural Cell Install
- Test Suite 11 – Nortel Metro Cell MFRM 1900 MHz Install
- Test Suite 12 – Nortel Metro Cell MFRM 800 MHz Install

Test Suites 1, 3, 5, and 7 are similar to Test Suites 0, 2, 4, and 6, but each includes additional TESTs for more rigorous and varied testing required in troubleshooting.

In some instances in the Test Suites, it is recommended that you record the test data using a personal computer (PC). See [“Handling Test Results” on page 62](#) for information on setting up and using a PC for recording data. So as to keep all data together for later use, it is recommended that you create a directory for each Base Station on the PC hard disk. Store all data files and screen captures for a particular Base Station in this directory for printing reports and reviewing test data.

However, if you would rather record test results on a service provider’s form, ignore any steps that direct you to press the **k3 (Save Data)** key. Instead, hand-write the data on the form.

These Test Suites are described briefly in the following sections. For more detailed information, refer to the Nortel Installation Methods.

Test Suite 0 – Nortel CDMA 1900 MHz Install

This Test Suite is used for installation of Nortel Legacy 1900-MHz Base Stations. It functions as a comprehensive Test Suite for commissioning the subject Base Stations, and includes the standard TESTs required for Base Station installation.

The suite includes the following TESTs:

- Measure Test Cable Loss
- Determine Cable Insertion Loss Factors
- Spectral Interference Evaluation
- RF Power Sensor Verification
- Code Domain Measurements
- Receiver Path Verification

All of these TESTs are listed on the Test Menu screen, and may be invoked from that screen one at a time, in any order.

Test Suite 1 — CDMA 1900 MHz Install

This Test Suite is used for installation and troubleshooting of Nortel Legacy 1900-MHz Base Stations. It functions as a comprehensive Test Suite for commissioning the subject Base Stations, and includes the standard tests required for Base Station installation, plus additional TESTs that may be used for installation troubleshooting.

The suite includes the following TESTs:

- Measure Test Cable Loss
- Determine Cable Insertion Loss Factors
- Spectral Interference Evaluation
- RF Power Sensor Verification
- Pilot Only Check
- Code Domain Measurements
- Go to Code Domain Analyzer
- Spectral Regrowth Test
- Go to Spectrum Analyzer
- Receiver Path Verification

All of these TESTs are listed on the Test Menu screen, and may be invoked from that screen one at a time, in any order.

Test Suite 2 — Nortel CDMA C800 Install

This Test Suite is used for installation of Nortel Legacy 800-MHz Base Stations. It functions as a comprehensive Test Suite for commissioning the subject Base Stations, and includes the standard TESTs required for Base Station installation.

The suite includes the following TESTs:

- Measure Test Cable Loss
- Spectral Interference Evaluation
- RF Power Sensor Verification
- Code Domain Measurements
- Receiver Path Verification

All of these TESTs are listed on the Test Menu screen, and may be invoked from that screen one at a time, in any order.

Test Suite 3 — CDMA C800 Install

This Test Suite is used for installation and troubleshooting of Nortel Legacy 800-MHz Base Stations. It functions as a comprehensive Test Suite for commissioning the subject Base Stations, and includes the standard tests required for Base Station installation, plus additional TESTs that may be used for installation troubleshooting.

The suite includes the following TESTs:

- Measure Test Cable Loss
- Spectral Interference Evaluation
- RF Power Sensor Verification
- Pilot Only Check
- Code Domain Measurements
- Go to Code Domain Analyzer
- Spectral Regrowth Test
- Go to Spectrum Analyzer
- Receiver Path Verification

All of these TESTs are listed on the Test Menu screen, and may be invoked from that screen one at a time, in any order.

Test Suite 4 — Nortel CDMA Macro Install

This Test Suite is used for installation of Nortel Legacy Macro Base Stations. It functions as a comprehensive Test Suite for commissioning the subject Base Stations, and includes the standard TESTs required for Base Station installation.

The suite includes the following TESTs:

- Measure Test Cable Loss
- Spectral Interference Evaluation
- RF Power Sensor Verification
- Code Domain Measurements
- Receiver Path Verification

All of these TESTs are listed on the Test Menu screen, and may be invoked from that screen one at a time, in any order.

Test Suite 5 — CDMA Macro Install

This Test Suite is used for installation and troubleshooting of Nortel Legacy Macro Base Stations. It functions as a comprehensive Test Suite for commissioning the subject Base Stations, and includes the standard tests required for Base Station installation, plus additional TESTs that may be used for installation troubleshooting.

The suite includes the following TESTs:

- Measure Test Cable Loss
- Spectral Interference Evaluation
- RF Power Sensor Verification
- Pilot Only Check
- Code Domain Measurements
- Go to Code Domain Analyzer
- Spectral Regrowth Test
- Go to Spectrum Analyzer
- Receiver Path Verification

All of these TESTs are listed on the Test Menu screen, and may be invoked from that screen one at a time, in any order.

Test Suite 6 — Nortel CDMA FCP800 Install

This Test Suite is used for installation of Nortel Legacy FCP 800-MHz Base Stations. It functions as a comprehensive Test Suite for commissioning the subject Base Stations, and includes the standard TESTs required for Base Station installation.

The suite includes the following TESTs:

- Measure Test Cable Loss
- Spectral Interference Evaluation
- RF Power Sensor Verification
- Code Domain Measurements
- Receiver Path Verification

All of these TESTs are listed on the Test Menu screen, and may be invoked from that screen one at a time, in any order.

Test Suite 7 — CDMA FCP800 Install

This Test Suite is used for installation and troubleshooting of Legacy FCP 800-MHz Base Stations. It functions as a comprehensive Test Suite for commissioning the subject Base Stations, and includes the standard tests required for Base Station installation, plus additional TESTs that may be used for installation troubleshooting.

The suite includes the following TESTs:

- Measure Test Cable Loss
- Spectral Interference Evaluation
- RF Power Sensor Verification
- Pilot Only Check
- Code Domain Measurements
- Go to Code Domain Analyzer
- Spectral Regrowth Test
- Go to Spectrum Analyzer
- Receiver Path Verification

All of these TESTs are listed on the Test Menu screen, and may be invoked from that screen one at a time, in any order.

Test Suite 8 — Nortel Metro Cell 1900 MHz Install

This Test Suite is used for installation of Nortel Metro Cell 1900-MHz Base Stations. It contains one group of TESTs for commissioning the subject Base Stations. The group includes the following TESTs:

- Measure Test Cable and Attenuator Loss
- Measure Device Loss
- Spectral Interference Evaluation
- Test Set Calibration and PAM Warm-Up
- Check Pilot, Paging, Sync, and OCNS
- MCPA RMS Power Sensor Verification
- Code Domain Channel Test
- OCNS Channels Code Domain Measurements
- Spectral Regrowth Test
- Adjacent Channel Power Test
- RX0 Receive Power Test
- RX0 Receive FER Test
- RX1 Receive Power Test
- RX1 Receive FER Test
- RX0 Receive Path Gain Test
- RX1 Receive Path Gain Test

All of these TESTs are listed on the Test Menu screen, and may be invoked from that screen one at a time, in any order.

Test Suite 9 — Nortel Metro Cell 800 MHz Install

This Test Suite is used for installation of Nortel Metro Cell 800-MHz Base Stations. It contains one group of TESTs for commissioning the subject Base Stations. The group includes the following TESTs:

- Measure Test Cable and Attenuator Loss
- Measure Device Loss
- Spectral Interference Evaluation
- Test Set Calibration and PAM Warm-Up
- Check Pilot, Paging, Sync, and OCNS
- HIP-D Power Sensor Verification
- Code Domain Channel Test
- OCNS Channels Code Domain Measurements
- Spectral Regrowth Test
- Adjacent Channel Power Test
- RX0 Receive Power Test
- RX0 Receive FER Test
- RX1 Receive Power Test
- RX1 Receive FER Test
- RX0 Receive Path Gain Test
- RX1 Receive Path Gain Test

All of these TESTs are listed on the Test Menu screen, and may be invoked from that screen one at a time, in any order.

Test Suite 10 — Nortel Rural Cell Install

This Test Suite is used for installation of Nortel Rural Cell Base Stations. It contains one group of TESTs for commissioning the subject Base Stations. The group includes the following TESTs:

- Measure Test Cable and Attenuator Loss
- Measure Device Loss
- Spectral Interference Evaluation
- Test Set Calibration and PAM Warm-Up
- Check Pilot, Paging, Sync, and OCNS
- MCPA RMS Power Sensor Verification
- Code Domain Channel Test
- OCNS Channels Code Domain Measurements
- Spectral Regrowth Test
- Adjacent Channel Power Test
- RX0 Receive Power Test
- RX0 Receive FER Test
- RX1 Receive Power Test
- RX1 Receive FER Test
- RX0 Receive Path Gain Test
- RX1 Receive Path Gain Test

All of these TESTs are listed on the Test Menu screen, and may be invoked from that screen one at a time, in any order.

Test Suite 11 — Nortel Metro Cell MFRM 1900 MHz Install

This Test Suite is used for installation of Nortel Metro Cell MFRM 1900-MHz Base Stations. It contains one group of TESTs for commissioning the subject Base Stations. The group includes the following TESTs:

- Measure Test Cable and Attenuator Loss
- Measure Device Loss
- Spectral Interference Evaluation
- Test Set Calibration and PAM Warm-Up
- Check Pilot, Paging, Sync, and OCNS
- HIP-D Power Sensor Verification
- Code Domain Channel Test
- OCNS Channels Code Domain Measurements
- Spectral Regrowth Test
- Adjacent Channel Power Test
- RX0 Receive Power Test
- RX0 Receive FER Test
- RX1 Receive Power Test
- RX1 Receive FER Test
- RX0 Receive Path Gain Test
- RX1 Receive Path Gain Test
- Multiple Carrier Test Menu

If you selected the **Multiple Carrier Test Menu** field **Choices:** list, the group includes the following two TESTs:

- MFRM Total Output Power Test
- Spectral Regrowth Test

All of these TESTs are listed on the Test Menu screen, and may be invoked from that screen one at a time, in any order.

Test Suite 12 — Nortel Metro Cell MFRM 800 MHz Install

This Test Suite is used for installation of Nortel Metro Cell MFRM 800-MHz Base Stations. It contains one group of TESTs for commissioning the subject Base Stations. The group includes the following TESTs:

- Measure Test Cable and Attenuator Loss
- Measure Device Loss
- Spectral Interference Evaluation
- Test Set Calibration and PAM Warm-Up
- Check Pilot, Paging, Sync, and OCNS
- HIP-D Power Sensor Verification
- Code Domain Channel Test
- OCNS Channels Code Domain Measurements
- Spectral Regrowth Test
- Adjacent Channel Power Test
- RX0 Receive Power Test
- RX0 Receive FER Test
- RX1 Receive Power Test
- RX1 Receive FER Test
- RX0 Receive Path Gain Test
- RX1 Receive Path Gain Test
- Multiple Carrier Test Menu

If you selected the **Multiple Carrier Test Menu** field **Choices:** list, the group includes the following two TESTs:

- MFRM Total Output Power Test
- Spectral Regrowth Test

All of these TESTs are listed on the Test Menu screen, and may be invoked from that screen one at a time, in any order.

Parameter Descriptions

Parameters are used to define the conditions under which a TEST will run. You may edit parameters to change default values or to meet specific test requirements and conditions. Each parameter may be used in one TEST or more. For information on editing parameters, see “Customizing Test Procedures” on page 50.

Parameters remain in battery-backed-up memory until you select a procedure to run. If you wish to prevent parameters from being lost when a new procedure is selected, save those in a procedure. See “Saving/Deleting Procedures to/from a Card” on page 57.

The list of parameters is arranged alphabetically. The first two letters in the title of each parameter indicate its classification. The classifications are:

- GN – General
- RX – Receiver
- ZZ – Demonstration mode

PARAMETER 1 — GN Band [0=North Amer 1-Korean]

Enter the desired control choice to determine the frequency band. Select 0 for the North American band; select 1 for the Korean band.

NOTE

This parameter operates as the default setting to automatically set the **Channel Standard** field on the Configuration Menu screen to the same setting when any procedure is initiated. If you change the **Channel Standard** field to the other setting while running a particular procedure, the Test Software will operate with that new setting until you initiate another procedure.

PARAMETER 2 — GN Display Drawings [0=no 1=yes]

Enter the desired control choice to determine whether connection drawings will be displayed at appropriate points in the testing process. Select 0 for no drawing display; select 1 for drawing display.

NOTE

This parameter operates as the default setting to automatically set the **Show Drawings with Tests** field on the More screen to the same setting when any procedure is initiated. If you change the **Show Drawings with Tests** field to the other setting while running a particular procedure, the Test Software will operate with that new setting until you initiate another procedure.

PARAMETER 3 — GN Spectral Check with LNA [0=no 1=yes]

Enter the desired control choice to determine whether the Test Software will perform a spectrum check using an external low-noise amplifier for evaluating low-level signals. Select 0 if you do not wish to use an external LNA; select 1 if you wish to use an external LNA.

Parameter Descriptions

NOTE

This parameter operates as the default setting to automatically set the **Use LNA for Spec Interfer** field on the More screen to the same setting when any procedure is initiated. If you change the **Use LNA for Spec Interfer** field to the other setting while running a particular procedure, the Test Software will operate with that new setting until you initiate another procedure.

PARAMETER 4 — GN Stop Test if Results Fail [0=no 1=yes]

Enter the desired control choice to determine the testing status in the event that a TEST fails during the test sequence. Select 0 to continue testing on a failure; select 1 to stop on a failure.

If you select 1, stop on failure when testing, the USER keys on the Test Set will provide choices on how to proceed. Press the associated keys for the following:

- **Proceed** - The Test Software will proceed with testing despite the failed data point. The next test of the sequence will be performed.
- **Repeat** - The Test Set will perform the same TEST again and post the results. If the test fails again, the Test Software will again offer these three options.
- **Abort** - The Test Software will stop the Baseline testing. If tests remain in the Baseline test sequence, those will not be performed. A summary of the number of passed and failed tests will be printed.

PARAMETER 5 — GN Test Type [Enter number on Conf Menu]

Enter the desired control choice for the test sequence that is to be used for testing the Base Station. The numbers to be entered correspond to the those on the **Choices:** list that appears when you select the **Test Type** field on the Configuration Menu screen.

NOTE

This parameter operates as the default setting to automatically set the **Test Type** field on the Configuration Menu screen to the same setting when any procedure is initiated. If you change the **Test Type** field to another setting while running a particular procedure, the Test Software will operate with that new setting until you initiate another procedure.

PARAMETER 6 — RX RF Level for Frame Error Rate (FER)

NOTE

This parameter is applicable to Metro Cell and Rural Cell Base Stations only.

Enter the level at which RF is to be injected into the Metro Cell or Rural Cell receiver during the Frame Error Rate (FER) test.

PARAMETER 7 — RX RF Level for RX Power Test

NOTE

This parameter is applicable to Metro Cell and Rural Cell Base Stations only.

Enter the level at which RF is to be injected into the Metro Cell or Rural Cell receiver during the RX power test.

PARAMETER 8 — ZZ Demo Mode [0=no 1=yes]

Enter the desired control choice to determine whether the Test Software will operate in normal mode or demonstration mode. Select 0 for operation in normal mode; select 1 for operation in demonstration mode. If you select 1, the Test Software will not actually perform measurements, but will display simulated data on the screen. This mode is useful if you are working in a training or practice situation without a Base Station attached to the Test Set.

As an operational safety feature, the Test Software will display the following message in large type on the TESTS (IBASIC Controller) screen when you select the **Run Test** field or press the **k1 (Run Test)** key after selecting demo mode:

THE SOFTWARE IS IN DEMO MODE.

Pass/Fail Limits Descriptions

Pass/fail limits define the values with which measurement results are compared to determine if the system under test meets specified standards.

For information on editing Pass/Fail Limits, see [“Customizing Test Procedures” on page 50](#).

All pass/fail limits include lower and upper limits that may be entered or modified. The column labeled **Check** on the TESTS (Pass/Fail Limits) screen allows you to specify whether the lower limit, the upper limit, or both of the limits will be used when compared with measurements. Some of the default pass/fail limits provided in the Test Software include only one of the limits. If you enter the other limit, make certain that you change the **Check** column to **Both**.

Pass/fail limits remain in battery-backed-up memory until you select a procedure to run. If you wish to prevent pass/fail limits from being lost when a new procedure is selected, save those in a procedure. See [“Saving/Deleting Procedures to/from a Card” on page 57](#).

Pass/fail limits may be secured (see [“Securing a Procedure” on page 83](#) and [“Un-Securing a Procedure” on page 84](#)).

The list of pass/fail limits is arranged alphabetically. The first two letters in the title of each pass/fail limit indicate its classification. The classifications are:

- RX – Receiver
- TX – Transmitter

PASS/FAIL LIMIT 1 — RX Frame Error Rate (FER)

Enter the upper pass/fail limit in percentage for the acceptable rates in the Frame Error Rate TEST for Metro Cell or Rural Cell Base Stations.

PASS/FAIL LIMIT 2 — RX Gain 1900 MHz

Enter the upper and lower pass/fail limits in dB for the RX gain in the Receiver Path Verification TEST for the Legacy 1900-MHz Base Station.

PASS/FAIL LIMIT 3 — RX Gain C800

Enter the upper and lower pass/fail limits in dB for the RX gain in the Receiver Path Verification TEST for the Legacy C800-MHz Base Station.

PASS/FAIL LIMIT 4 — RX Gain FCP800

Enter the upper and lower pass/fail limits in dB for the RX gain in the Receiver Path Verification TEST for the Legacy FCP 800-MHz Base Station.

PASS/FAIL LIMIT 5 — RX Gain Macro

Enter the upper and lower pass/fail limits in dB for the RX gain in the Receiver Path Verification TEST for the Legacy Macro Base Station.

PASS/FAIL LIMIT 6 — RX Gain Metro 1900 MHz thru No TRM

Enter the upper and lower pass/fail limits in dB for the RX gain in the Receive Path Gain Verification TEST for the Metro Cell 1900-MHz Base Station. This gain is from the DPM input to the cable connected to the RX0/RX1 input of the TRM.

PASS/FAIL LIMIT 7 — RX Gain Metro 1900 MHz thru One TRM

Enter the upper and lower pass/fail limits in dB for the RX gain in the Receive Path Gain Verification TEST for the Metro Cell 1900-MHz Base Station. This gain is from the DPM input through one TRM to the RX0/RX1 output of the TRM.

PASS/FAIL LIMIT 8 — RX Gain Metro 1900 MHz thru Three TRMs

Enter the upper and lower pass/fail limits in dB for the RX gain in the Receive Path Gain Verification TEST for the Metro Cell 1900-MHz Base Station. This gain is from the DPM input through three TRMs to the RX0/RX1 output of the TRM.

PASS/FAIL LIMIT 9 — RX Gain Metro 1900 MHz thru Two TRMs

Enter the upper and lower pass/fail limits in dB for the RX gain in the Receive Path Gain Verification TEST for the Metro Cell 1900-MHz Base Station. This gain is from the DPM input through two TRMs to the RX0/RX1 output of the TRM.

PASS/FAIL LIMIT 10 — RX Gain Metro 800 MHz Div thru One TRM

Enter the upper and lower pass/fail limits in dB for the RX gain in the Receive Path Gain Verification TEST for the Metro Cell 800-MHz or Rural Cell Base Station. This gain is from the DPM input through one TRM to the RX0/RX1 output of the TRM.

PASS/FAIL LIMIT 11 — RX Gain Metro 800 MHz Div thru No TRM

Enter the upper and lower pass/fail limits in dB for the RX gain in the Receive Path Gain Verification TEST for the Metro Cell 800-MHz or Rural Cell Base Station. This gain is from the DPM input to the cable connected to the RX0/RX1 output of the TRM.

PASS/FAIL LIMIT 12 — RX Loss 1:2 Splitter Metro 1900 MHz

Enter the upper and lower loss limits in dB for the external 1:2 splitter in the Metro Cell 1900-MHz Base Station.

PASS/FAIL LIMIT 13 — RX Loss 1:2 Splitter Metro 800 MHz

Enter the upper and lower loss limits in dB for the external 1:2 splitter in the Metro Cell 800-MHz Base Station.

PASS/FAIL LIMIT 14 — RX Loss 1:4 Splitter Metro 800 MHz

Enter the upper and lower loss limits in dB for the external 1:4 splitter in the Metro Cell 800-MHz or Rural Cell Base Station.

PASS/FAIL LIMIT 15 — RX Loss 1:6 Splitter Metro 800 MHz

Enter the upper and lower loss limits in dB for the external 1:6 splitter in the Metro Cell 800-MHz or Rural Cell Base Station.

PASS/FAIL LIMIT 16 — RX Loss LPP and Cable Metro 800/1900 MHz

Enter the upper and lower loss limits in dB for the lightning protection plate (LPP) and its cable in the Metro Cell Base Station.

PASS/FAIL LIMIT 17 — RX Loss TRM Splitter Metro 1900 MHz

Enter the upper and lower loss limits in dB for the splitter in the TRM in the Metro Cell 1900-MHz Base Station.

PASS/FAIL LIMIT 18 — RX Power Gain Metro Cell

Enter the upper and lower pass/fail limits in dB for the RX gain in the Receive Power Test for the Metro Cell or Rural Cell Base Station.

PASS/FAIL LIMIT 19 — TX Adjacent Channel Pow at 750 kHz Offsets

Enter the upper pass/fail limit in dB for the ratio of the transmitter power in the adjacent channel (at both the + and -750-kHz offsets) to the power of the desired signal. This specification is used in the Spectral Regrowth Test and the Adjacent Channel Power Test in Metro Cell 800-MHz or Rural Cell Base Stations.

PASS/FAIL LIMIT 20 — TX Adjacent Channel Pow at 885 kHz Offsets

Enter the upper pass/fail limit in dB for the ratio of the transmitter power in the adjacent channel (at both the + and -885-kHz offsets) to the power of the desired signal. This specification is used in the Spectral Regrowth Test and the Adjacent Channel Power Test in Metro Cell 1900-MHz Base Stations.

PASS/FAIL LIMIT 21 — TX Code Domain Carrier Feedthru

Enter the upper pass/fail limit in dB for the carrier feedthrough in Code Domain Measurements in Legacy Base Stations.

PASS/FAIL LIMIT 22 — TX Code Domain Carrier Feedthru Metro

Enter the upper pass/fail limit in dB for the carrier feedthrough in Code Domain Measurements in Metro Cell and Rural Cell Base Stations.

PASS/FAIL LIMIT 23 — TX Code Domain Frequency Error

Enter the upper and lower pass/fail limits in Hz for the frequency error in Code Domain Measurements in Legacy Base Stations.

PASS/FAIL LIMIT 24 — TX Code Domain Frequency Error Metro

Enter the upper and lower pass/fail limits in hertz for the frequency error in Code Domain Measurements in Metro Cell and Rural Cell Base Stations.

PASS/FAIL LIMIT 25 — RX Code Domain Rho

Enter the lower pass/fail limit in decimal units for the rho in Code Domain Measurements in Legacy Base Stations.

PASS/FAIL LIMIT 26 — RX Code Domain Rho Metro Cell

Enter the lower pass/fail limit in decimal units for the rho in Code Domain Measurements in Metro Cell and Rural Cell Base Stations.

PASS/FAIL LIMIT 27 — TX Code Domain Time Offset

Enter the upper and lower pass/fail limit in μsec for the time offset in Code Domain Measurements in Legacy Base Stations.

PASS/FAIL LIMIT 28 — TX Code Domain Time Offset Metro Cell

Enter the upper and lower pass/fail limit in μsec for the time offset in Code Domain Measurements in Metro Cell and Rural Cell Base Stations.

PASS/FAIL LIMIT 29 — TX Code Domain Time Offset w/IMF or Comb

Enter the upper and lower pass/fail limit in μsec for time offset in Code Domain Measurements TESTs for Metro Cell 800-MHz and Rural Cell Base Stations with an IMF filter or TX combiner.

PASS/FAIL LIMIT 30 — TX Emission Bandwidth

Enter the bandwidth (in the upper limit field) in MHz to be used for the two points centered around the carrier, outside of which all emissions must be attenuated to at least 26 dB below the carrier transmit power.

PASS/FAIL LIMIT 31 — TX Inactive Code Channel Maximum Level

Enter the upper pass/fail limit in dB for the maximum allowable inactive Walsh code level in the Highest Inactive Code Domain Channel Test in the Code Domain Channel Test.

PASS/FAIL LIMIT 32 — TX Pilot Only Maximum Unused Walsh Codes

Enter the upper pass/fail limit in dB for the threshold level for determining whether a Walsh code is active or inactive in the Pilot Only Check.

PASS/FAIL LIMIT 33 — TX Power Error 1900 MHz

Enter the upper and lower pass/fail limits in dB for the power error in the RF Power Sensor Verification test for Legacy 1900-MHz Base Stations.

PASS/FAIL LIMIT 34 — TX Power Error at Temp Extremes 1900 MHz

Enter the upper and lower pass/fail limits in dB for the power error at temperatures below 50° F or above 85° F in the RF Power Sensor Verification test for Legacy 1900-MHz Base Stations. This specification is effective only if a temperature outside of the normal range is selected in the More screen.

PASS/FAIL LIMIT 35 — TX Power Error C800

Enter the upper and lower pass/fail limits in dB for the power error in the RF Power Sensor Verification test for Legacy C800 Base Stations.

PASS/FAIL LIMIT 36 — TX Power Error FCP800

Enter the upper and lower pass/fail limits in dB for the power error in the RF Power Sensor Verification test for Legacy FCP800 Base Stations.

PASS/FAIL LIMIT 37 — RX Power Error Macro

Enter the upper and lower pass/fail limits in dB for the power error in the RF Power Sensor Verification test for Legacy Macro Base Stations.

PASS/FAIL LIMIT 38 — TX Power Error Metro Cell 1900 MHz

Enter the upper and lower pass/fail limits in dB for the power error in the HIP-D Power Sensor Verification test for Metro Cell 1900-MHz Base Stations.

PASS/FAIL LIMIT 39 — TX Power Error Metro Cell 800 MHz

Enter the upper and lower pass/fail limits in dB or the power error in the HIP-D Power Sensor Verification test for Metro Cell 800-MHz or Rural Cell Base Stations.

PASS/FAIL LIMIT 40 — TX Power Error Metro Cell MFRM 1900 MHz

Enter the upper and lower pass/fail limits in dB for the power error in the MCPA RMS Power Sensor Verification test of power levels ≥ 32 dBm for Metro Cell MFRM 1900-MHz Base Stations.

PASS/FAIL LIMIT 41 — TX Power Error Metro Cell MFRM 800 MHz

Enter the upper and lower pass/fail limits in dB or the power error in the MCPA RMS Power Sensor Verification test of power levels ≥ 33 dBm for Metro Cell MFRM 800-MHz Base Stations.

PASS/FAIL LIMIT 42 — TX Power Error Rural Cell 800 MHz

Enter the upper and lower pass/fail limits in dB for the power error in the HIP-D Power Sensor Verification test for Rural Cell 800-MHz Base Stations.

PASS/FAIL LIMIT 43 — TX Power Loss Combiner Metro 800 MHz

Enter the upper and lower loss limits in dB for the Metro Cell 800-MHz or Rural Cell Combiner.

PASS/FAIL LIMIT 44 — TX Power Loss IMF Metro Cell 800 MHz

Enter the upper and lower loss limits in dB for the Metro Cell 800-MHz or Rural Cell IMF filter.

PASS/FAIL LIMIT 45 — TX Power Loss LPP & Cable Metro 1900 MHz

Enter the upper and lower loss limits in dB for the Metro Cell 1900-MHz lightning protection plate (LPP) and cable.

PASS/FAIL LIMIT 46 — TX Power Loss LPP & Cable Metro 800 MHz

Enter the upper and lower loss limits in dB for the Metro Cell 800-MHz lightning protection plate (LPP) and cable.

PASS/FAIL LIMIT 47 — TX Power Error MFRM 1900 MHz <32 dBm

Enter the upper and lower pass/fail limits in dB for the power error in the MCPA RMS Power Sensor Verification test of power levels < 32 dBm for Metro Cell MFRM 1900-MHz Base Stations.

PASS/FAIL LIMIT 48 — TX Power Error MFRM 800 MHz <33 dBm

Enter the upper and lower pass/fail limits in dB or the power error in the MCPA RMS Power Sensor Verification test of power levels < 33 dBm for Metro Cell MFRM 800-MHz Base Stations.

Numerics

1-800 help line, 13

A

Accessory Kit Cables, Connectors,
and Small Accessories, 34
additional services available, 13

B

blossoming the Base Station, 92
BTS utility
 sending test results to a PC, 62

C

cell site to test set connections, 36
changing pass/fail limits, 54
changing test parameters, 51
Configuration Menu screen fields
 Sector, 22
Configuration Menu screen, 21
 selection descriptions, 21
Configuration Menu screen fields
 Base Station PN Offset, 22
 Cabinet, 23
 Carr Conf, 23
 Channel, 21
 Channel Standard, 22
 External Attenuator Loss, 23
 RX Conf, 24
 Test Cable 1 (TC1) Loss, 23
 Test Cable 2 (TC2) Loss, 23
 Test Menu, 21
 Test Results/Laptop
 Util/Printer/Serial Setup,
 24
 Test Type, 23
 TX Conf, 24
Configuratoin Menu screen fields
 Base Station Power Out, 22
 Carrier Power Out, 22
 CDMA Standard, 22
configuring the PC terminal
 program, 63, 67
connections
 cell site to test set, 36
customizing test procedures, 50

D

DATA ENTRY keys, 81
description
 parameters, 139
 pass/fail limits, 142
 test software, 10
destination devices, 62

E

equipment required, 34

F

Factory Hot Line, 13

G

GENERATOR/ANALYZER keys,
82

H

handling test results, 62
HP-IB printer
 sending test results to, 75
HP-IB printer connections, 47

I

initializing a PC card, 78
initializing a RAM disk, 77
initiating testing, 32
inserting a PCMCIA card
 first time, 17
items required, 12
items supplied in the software
 package, 11

K

keys
 DATA ENTRY, 81
 GENERATOR/ANALYZER, 82
 SOFTWARE, 80
 STATE, 82
 USER, 80
 UTIL, 82

L

loading a procedure
 first time, 17
loading the test software, 17

M

More screen, 27
More screen fields
 Alpha RX1/Jumper Loss to
 RFFE, 29
 Alpha TX/Jumper Loss to RFFE,
 29
 Beta RX1/Jumper Loss to RFFE,
 30
 Beta TX/Jumper Loss to RFFE,
 29
 Gamma RX1/Jumper Loss to
 RFFE, 30

Gamma TX/Jumper Loss to
 RFFE, 30
Return, 27
RFFE at Remote Location, 29
Show Drawings with Tests, 29
Site Name, 29
Use LNA for Spec Interfer, 29
Utilities Menu, 27

O

operating the test set, 79
overview
 test software, 16

P

parallel printer
 sending results to, 74
parallel printer connections, 47
parameter descriptions, 139
parameters
 changing, 51
part number
 base station connection kit, 12
part numbers
 test software PC cards, 11
 User's Guides, 11
pass number, 84
pass/fail limit specification
 descriptions, 142
pass/fail limits
 changing, 54
PC and printer connections, 46
PC card
 initializing, 78
PC connections, 46
printer
 stop sending test results to, 76
printers supported, 62
procedure
 securing, 83
 unsecuring, 84
procedures
 saving/deleting to/from an
 SRAM card, 57
 saving/deleting to/from internal
 RAM, 61
 securing/un-securing, 83
procedures supplied, 88

R

RAM disk
 initializing, 77
retrieving data from an SRAM
 card, 70
RF tools, 86

S

- saving/deleting procedures
 - to/from an SRAM card, 57
- saving/deleting procedures
 - to/from internal RAM, 61
- screens, 79
- securing a procedure, 83
- securing procedures, 83
- selections
 - Configuration Menu screen, 21
- sending test results to a parallel printer, 74
- sending test results to a PC, 66
- sending test results to a PC using the BTS utility, 62
- sending test results to a serial printer, 73
- sending test results to an HP-IB printer, 75
- sending test results to an SRAM card, 69
- sending the results, 65
- serial printer
 - sending results to, 73
- serial printer connections, 46
- setting up the test software, 21
- shift function, 79
- shift functions, 80
- SOFTWARE keys, 80
- SRAM card
 - retrieving data from, 70
- STATE keys, 82
- stop sending test results to a PC or an SRAM card, 73
- stop sending test results to a printer, 76
- supported printers, 62

T

- test descriptions, 91
- test procedures
 - customizing, 50
- test results
 - handling, 62
 - sending to a parallel printer, 74
 - sending to a PC, 66
 - sending to a PC using the BTS utility, 62
 - sending to a serial printer, 73
 - sending to an HP-IB printer, 75
 - sending to an SRAM card, 69
 - stop sending to a printer, 76
- test set
 - operating, 79
- test set to HP-IB printer
 - connection, 46

- test set to parallel printer
 - connection, 46
- test set to PC connection, 46
- test set to serial printer
 - connection, 46
- test software
 - loading, 17
 - overall description, 10
 - setting up, 21
- test software overview, 16
- test software package
 - items supplied, 11
- test suite descriptions, 129
- TEST SUITEs
 - descriptions, 129
- testing
 - initiating, 32
- testing MFRM Metro Cell Base Stations, 92
- TESTs
 - descriptions, 91
- tests results
 - stop sending to a PC or SRAM card, 73
- training
 - start up assistance, 13
- troubleshooting
 - test software loading, 20

U

- unsecuring a procedure, 84
- unsecuring procedures, 83
- Updated Software Service, 13
- USER keys, 80
- using the configuration menu screen, 21
- using the Test Menu screen, 31
- utilities, 86
 - description, 86
- UTILS keys, 82